

Drag Reduction 103

Techniques for Increasing Europa Performance Through Drag Reduction

By

Bud Yerly

Custom Flight Creations, Inc.

The Europa XS and Classic are very clean aircraft aerodynamically with a wide speed range from 50-160Knots. Many wonder why this aircraft is capable of such a wide speed range, and others are not.



First is the wing design. The wing is a laminar flow design with a tailored aspect ratio and excellent slow and high speed characteristics. The wing's twist allows it to fly at nearly an elliptic lift distribution and handle a wide range of loads without the need for aerodynamic gimmicks such as slats, vortex generators, winglets, etc. to create the lift necessary to haul 1370 lbs. and as much as 1450 lbs. at surprisingly high speeds. The wing provides low drag for efficient cruise at low power settings, or it allows high speed for the guy with get there itis.

Second, is a low drag high power empennage or tail volume. The all moving tail plane creates large forces for CG control and maneuvering, while giving excellent feedback or feel as the plane is maneuvered throughout its envelope.



The tailplanes symmetrical Series 6 laminar flow airfoil creates a drag bucket which allows a degree or two of trim angle without increasing the parasite drag. Although the tailplane lift downward of course increases the main wing angle of attack and increases overall drag.

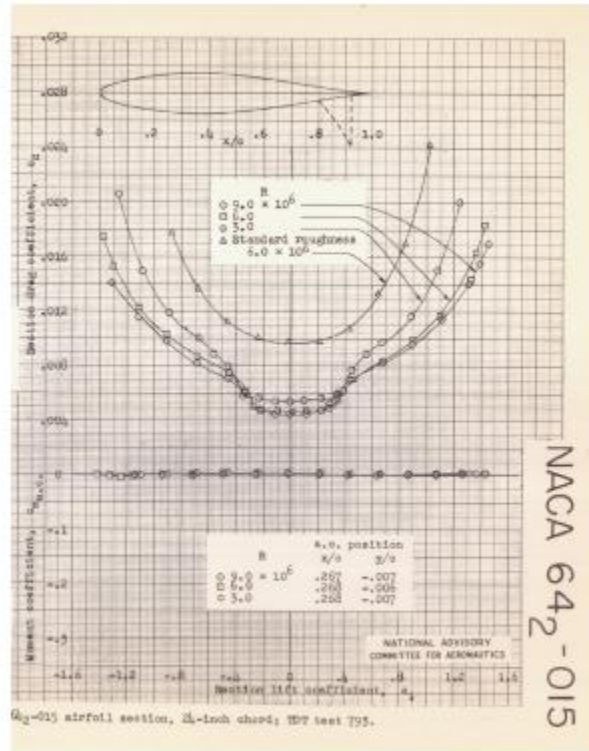

The fin is large, and the rudder aft of the tail plane, which creates a responsive rudder which is effective down to 35 knots.

Third is a clean fuselage shape. The fuselage has a tapered neck down aft of the cockpit to reduce weight and allow some pressure recovery while preserving a generous passenger and cargo compartment. The fuselage layout with the short nose, passenger weight being slightly ahead of the CG and fuel being slightly behind the CG, creates a center of mass very close to the aerodynamic center. This makes the aircraft very easy to maneuver without the drag losses due to large control movements.

Fourth it is a smooth composite skin. Parasite drag is the killer of most light aircraft. The composite skin (if properly finished), allows for a very smooth surface and when clean and waxed is as near to a perfect wind tunnel model as one can hope for.

Fifth is, the aircraft kit does have additional drag reduction fairings for improved performance. The Trigear has reasonable pressure recovery wheel covers and basic nose and main gear fairings. The retractable mono wheel with wing and a fuselage fairing gave the Europa its best speed in class for a number of years. The wing flap brackets on both versions were draggy so simple covers were offered to smooth out these drag producers. The mono may need special trailers, hoisting equipment and has somewhat

quirky ground characteristics but it is light. The Trigear aircraft made a much easier to handle aircraft on the ground but at a significant weight and drag penalty.

Drag of the three sticks in the air (landing gear) is a problem for all Trigear fixed gear aircraft, but with the advent of pressure recovery/laminar gear leg covers, wheel pants and smooth fuselage to gear transition fairings makes the difference in speed between the Mono and Trigear to be only about 5-10 knots. The difference in speed is primarily the height of the pants, transition fairings, and weight change of the aircraft. Keep the pants low, make smooth transitions, and keep the plane light, and the difference in speed is quite small. The Lancair, Sircus SR22, Cessna Conquest and other composite aircraft have shown that a comfortable speed increase with proper cleanup of the gear will overcome the complexity and weight of a tricycle gear retractable.

Wheel Pant and transition fairing:



Cooling drag is a big problem and accounts for most of the drag of light aircraft. All the composite aircraft manufacturers (with the exception of most experimental kit aircraft) work very hard to reduce cooling drag. Your Europa/Rotax firewall forward actually has nearly everything you needed to minimize the cooling drag, but it requires some attention to detail.

The NACA, now NASA, Technical reports from the 30s through WWII chronicled the principals necessary to achieve proper cooling, while at the same time reducing drag losses. The Thorpe T-18 and Mustang II were the first two of the experimental aircraft to work on this cooling drag issue. Today, Lancairs Fred Morenos excellent work on reducing cooling in that airplane, Harmen Koffman's book on light airplane drag, and of course the books by Bruce Carmichael on drag reduction are all excellent sources to target specific types of drag reduction.

I wrote "Cooling 101" for the Europa Owners (and Europa Ltd) to show that the stock cowl was not only adequate but required only attention to detail of the builders to achieve good cooling and yield a subsequent reduction in drag without moveable flaps and additional plumbing. I was able to apply the above technical reports and information to improve a stock Trigear/914 with fixed pitch prop from 117 KTAS at 5500 RPM to 137 KTAS at 5500 RPM. For those with the Jabiru Engine, I wrote Cooling 102 which chronicled the cooling improvements, and the speed improvements of a stock Europa/Jabiru/fixed prop combination from 107 KTAS at 2900 RPM to 137 KTAS at 2900 RPM and a normal cruise of 125 KTAS at only 2650 RPM at 6 GPH.

So, if you built your Europa absolutely stock, what techniques or chores you can do to increase the speed of your existing stock Europa? In order one should:

1. Clean the aircraft. The skin should be free of any dirt, bugs and crap. Once cleaned, a good buffing and wax makes a huge difference. If you don't know how to use a buffer, hire somebody. If the paint is really bad consider a light re-sand and thin coat of fresh paint. Body shops have to sand and buff nearly all these new urethane finishes as they orange peel badly. They can do it for you, or teach you.

A slick paint job helps immensely. However, your stall characteristics are going to change as the airfoil is now going to hold on to the boundary layer a little longer and when it separates, boom it breaks. It will be imperative that you pay attention to the rudder or ball as you approach the stall as the wing will probably drop with the ball. Consider installing stall strips at the root per the Operators Handbook if not already installed.



2. Trim out the aircraft. If the wing incidence or sweep is off, or the flaps are drooping and the ball is out, fix it. If the flaps are a 1/2 inch below the wing during build, fix it. See Europa Trimming on my website.

3. CG. All that extra stuff guys add tends to load up the nose. The Europa is best if its empty wt. CG is between 60 and 61 inches.

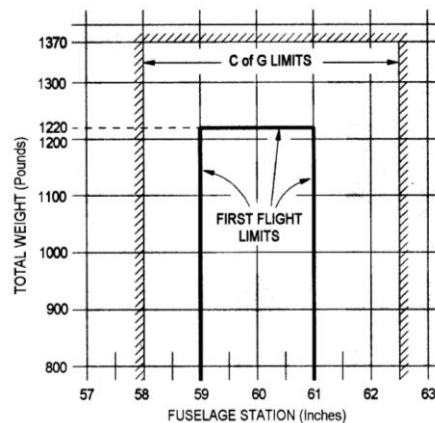

If the CG is farther forward the tail plane has to pull down to hold the nose up. One degree of tail plane pitch down requires the main wing to be at a higher angle of attack, to compensate for the load of the tail plane. Since the tail plane is 20% of the wing area, the extra drag due to lift of the tail plane increases drag even more.

4. Gap Seals. In general, I have never seen gap seals effectively work if the aircraft is flying at its design angle of attack, and the gaps at the hinge line are small. If cruising at its design angle of attack, the pressure difference on the top of the aileron and flap gaps is not that great. Now in maneuvering, that is a different story. At high angles of attack a bad gap (over 1/16 inch) at the hinge line will cause flow problems. Just ask the glider guys. Gap seals work at high angles of attack getting into the thermal, but at high speed, not so much.

Flap and Aileron Tape



Wing gap seal tape.



Again, as long as the gaps are small, gap seals are not needed. Door seals are very important also, a lot of lift comes off the canopy, and a stream of air from inside the cockpit out the top disrupts this smooth low pressure air flow causing turbulent flow where smooth flow is needed most. Another area is the wing gap between the wing fillet and fuselage side. Any air leakage here adds significantly to this transition drag. I use a white D cell material (the photo above shows the tape as furnished) and is split into two.

5. Cooling drag. Every molecule of air that comes into the cowl must be controlled, do its job, and exit smoothly, just like a crowd. First, make sure the gap around the duct to the radiators is sealed completely. Seal the duct to the cowl bottom and front completely. Fabricate cowl seal and fiberglass dams to prevent airflow and pressure loss in the duct and reverse flow forward and up into the cowl but also allow easy install and removal of the cowl. It is important to pressurize this duct. Once the pressure builds in front of the radiator, a bubble of air forms around the nose and this smooths the flow around the cowl. The exit duct could stand to be a bit wider, but for the non turbo engines; cooling is not a problem, it's the drag. Seal the ducts. As for the front inlets, Rotax requires some airflow for the cylinder barrels. These front ducts also are positioned to keep the forward cylinder exhaust pipes from burning up the cowl. The Rotax supplied air diverter was considered necessary for cooling initially on the 912S, and Europa supplied a large inlet to be cut into the cowl to supply air to this duct. This was a large cowl hole

in the front, which fit to the cylinder tops as a plenum which proved on the Europa to be acceptable for increased airflow but at a drag penalty. In my experience, the added ducting and drag were both unnecessary.

Rotax 912S plenum and inlet.



6. Engine inlet air. The Bing Carbs. need cool air to function properly. Those of you using just cone shaped K&N filters attached directly to the carb with no inlet plenum, are now feeding your engine hot and low pressure cowl air. That is like running the aircraft at a higher density altitude. Make a cold air inlet, and gain a bit more power from your engine.

Cold air box

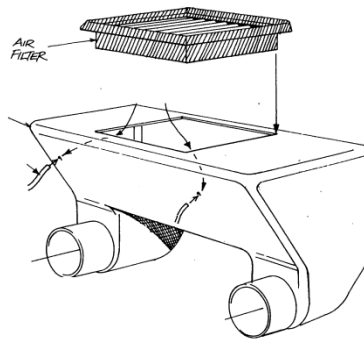

7. Parasite drag cleanup. If you were talked into external GPS NAV or radio antennas to be hung on the outside of the aircraft, pull out those heavy antennas, and their ground planes and install internal antennas. The AAE is an excellent choice for composite COM and NAV antennas sold through many outlets..

AAE Transponder Antenna



AAE Com Antennas



The flap brackets (especially the outers) are a huge drag source. So is the gear. Gear drag is interesting. The legs and brake calipers actually produce more drag than the tires and wheels.

Many have installed their Europa speed kit and found, it didn't work very well. It is all technique. Reference the NACA Reports at the end of this paper. Attention to detail is important:

a. Install the main gear pants absolutely aligned with the flight path and install the pants as low as you can for the runways you work off of. Install bulkheads in the pants to prevent dirt accumulation but also help out flow in the pant. Refer to NACA Report 485, which states: "3. The drag of the combination of a wheel and wheel fairing is due, in a large measure, to that portion of the wheel which protrudes from the fairing".

b. Install the gear leg covers rigid so they cannot flutter. A fluttering cover has 8 times the drag. One technique is to mold a transition fairing to hold the gear leg covers firmly but still allow gear movement.

c. Install transition fairings between the fuselage and the pants. Smooth the air around any transition between parts. Some use glider tape, but this is a temporary band aid. Use clay and mold a simple pleasing transition. Mold it so it has some space to allow some gear movement of the leg without cracking the glass. The wheel to leg transition can be built with as little as 1/16 inch clearance but the gear leg to fuselage transition need nearly ¼ inch all around for outward and fore and aft movement. Landing gear take a beating and shake a lot. Plan for it.

Reinforce all your wheel pant attachment points and install bulkheads inside the pants for strength and support. Normally a metal washer floxed and glassed in is enough. Reinforce the wheel opening with extra layers of glass. It is not a bad idea to curl in the cutout for the wheel to allow a smoother flow around the tire. Every little bit helps with drag and for longevity. I even made my wheel pants flip up to lower maintenance down time or preflight inspections, because if it takes time to do, folks won't do it.

d. Install a nose pant and leg cover. The fork on the nose gear is very draggy. Make this clean.



e. Pay attention to the alignment of the wing bracket speed kit covers. They have to be straight or you have six rudders out their producing drag.

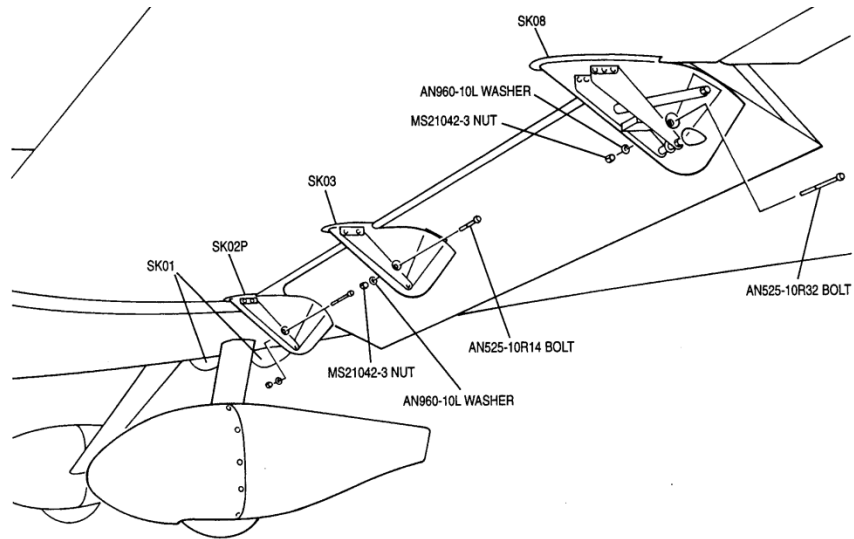

f. A mono wheel transition kit is a player also. The big tire is a considerable drag source. But buried half way into the fuselage it can help from a transition fairing.



The above are fairly low cost fixes but time consuming. The next ones cost more, a lot more:

8. Install a constant speed propeller. The best bang for the buck are the Whirlwind hydraulic and the Airmaster electric constant speed propellers (with Sensenich or Whirlwind blades). The Sensenich and Whirlwind blades in the Airmaster hubs are good for at least 10 knots on a typical 912 Europa and more on a 914. I am not a fan of a fixed pitch props as the Europa's speed range falls into the heart and soul of a constant speed prop. Good acceleration to get off quickly, faster climb to altitude, higher cruise at the engines optimum cruise power settings and a maximum top end are all possible with a constant speed prop.

Airmster Photo AP332 S



9. Buy a higher powered engine.
Rotax 914



The Europa is best when married to the Rotax 914, but the 912 and 912S are respectable performers also. I highly recommend you do not experiment on your engine by adding an after-market turbo, different pistons or other mods not recommended by the engine manufacturer. Most of the time, the engine's time between failures become quite short with these mods, whereas, the stock Rotax engine will normally go all the way to its time to overhaul.

10. Throw out the weight. Redo the instrumentation and interior. The chart below gives you an idea how a typical Europa Horsepower Required will shift with a change in altitude and a change in only 100 pounds of weight. We all know if you decrease the drag, the left side of the chart will shift further right, whereas a change in weight shifts the curve to the left which will increase stall speed, L/D max and max range speeds slightly higher and decrease top speed. If you don't need the weight, get rid of it. Your climb rate will be improved, reducing the fuel needed to get to altitude, and a parasite drag reduction increases the cruise speed.

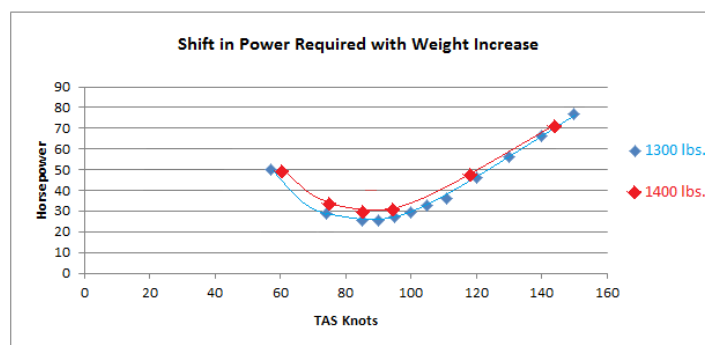
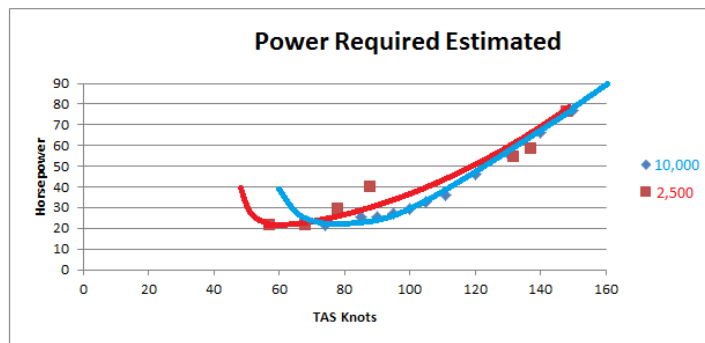

Heavy vacuum instruments, heavy boat interiors, heated or heavy cushions, massive electronics like the early Blue Mountain and its servos, old style S-tech autopilot servos, older Whelen lights and their boxes, older heavy Com Nav radios, fixed oxygen bottles, massive HID landing lights with their ballasts, rotating beacons, Stormscope lightning finders, large electric gyros for attitude, DG, turn and slip and the extra alternator to keep it all running are heavy items. Finally get rid of the marine or golf cart battery and Piper style external charging jack as they too make for a heavy bird. Read on for specifics.

Today's EFIS systems can do it all for far fewer pounds and less space. It is not uncommon to save as much as 25 pounds in just eliminating vacuum and electric gyro instruments such as the turn and bank, DG, Attitude indicator, and course indicators and replacing them with a single EFIS. If you are tech savvy, a simple tablet and free off the shelf software can be installed eliminating the need for maps and charts, and in a simple VFR aircraft, it will eliminate the complex and costly large EFIS units and older NAV/GPS units.

Interior treatments:

My cushions weigh 8 pounds for all four, Oregon Aero heated cushions weigh 5 pounds each or 20 pounds.

Paint the interior, or use a lighter interior fabric. Again, I use a super light headliner and little side padding with light weight carpet. As seen in the photo below, Jeff Roberts did his seats and sides in leather, however, the baggage bay is a matching paint and trim color with a carpet floor. Very tasteful and light...



Electrical.

As for other components, autopilots have been shrunk down considerably, the whole system may be run off the EFIS or a handheld GPS and only involve a 2 pound servo or two.

Exterior lighting is all LED low power now, cost effective and low power and drag.



Alternators are 5 to 8 pounds and expensive. Com radios and transponders are much lighter today and navigations systems can be put on your cell phone.

The Garmin 430 is only 8 pounds right, but the tray is another 2, and the 25 feet of cable, genuine Garmin GPS antennas, Garmin MK 106 and three VHF antennas comes to 25 pounds. Keep the Garmin and get rid of the peripherals and use lighter gear and antennas.

If you must fly IFR and install appropriate NAV radios and heated pitot systems, find other areas to reduce weight.

Get rid of the massive batteries. Today's Gel cells are ½ the weight and all the cranking amps. Lithium Ion are even lighter, but costly. Lead and gel cell batteries are good for about 3 years, and then the battery won't hold a charge well enough to spin up a low torque starter any longer. So the cost of replacement becomes a factor. I have extended the life of gel cells by going back to the dealer and having them cycled or de-sulfated which gives a much longer battery life. Go as light and cost effective to suit your needs.

Odyssey and Earth X Lithium ion batteries



Be an amp zealot. Cut the amps and you can cut out the extra alternator. External charging jacks can be much lighter. Use a simple Anderson Power Products connector and save significant weight and size over a standard Piper jack.

In conclusion:

To improve your performance, clean up your exterior first. Determine your aircrafts basic smooth polished speed. Check your weight and balance, and trim. Reduce interference drag such as gear and wheel pants/covers and flap brackets, wing gaps and door seals. Improve your cooling drag losses. Seal it up. Then look at your results. Finally, improve your propulsion with a larger engine and or a constant speed propeller.

Do your research and find out which is most cost effective for your bird. With lower drag comes extra speed, extra range, better fuel efficiency if at the same power settings, and a better glide ratio. It is a win/win situation.

References:

1. HOMEBUILT AIRCRAFT DRAG REDUCTION - Case Study with a Lancair IV – Part 1 © Copyright - Fred Moreno - January 2009 Rev. 1
2. The Cost* of Your Airplane's Parasite Drag and the Advantages of Airplane Drag Reduction by Harmen Koffeman, AeroDrag Publishing
3. The Design of the Europa Super Efficient Wing, by Don Dykins
4. NACA Reports: 485,518,522,818

Papers:

Cooling 101 and Cooling 102 by author.
Custom Flight Creations Wheel Pants by author.