



**Airmaster Propellers Ltd**

*High Performance Propeller Systems*

Airmaster Propellers Ltd  
20 Haszard Rd, Massey  
PO Box 374, Kumeu  
Auckland, New Zealand

Ph: +64 9 833 1794  
Fax: +64 8326 7887  
Email: [sales@propellor.com](mailto:sales@propellor.com)  
Web: [www.propellor.com](http://www.propellor.com)



AP3 SERIES AND AP4 SERIES  
CONSTANT SPEED PROPELLER  
OPERATOR'S MANUAL

## Revision control

<b>Revision</b>	<b>Change</b>	<b>Approved</b>	<b>Date</b>
1	Initial release	MJE	21Dec2001
2	Content revision	MJE	18Oct2006
3	Inclusion of 4 series	MJE	12Feb2010
4	Inclusion of reversing models	MJE	21Jan2013



Section 6.1.1.	Introduction .....	32
Section 6.1.2.	Manual Over-Ride Operation .....	32
Section 6.1.3.	Manual Feather Operation (Option) .....	33
Section 6.1.4.	Automatic Feather Operation (Option) .....	33
Section 6.1.5.	Automatic Beta Operation (Option) .....	34
<b>Part 6.2.</b>	<b>Engine Running Functional Check.....</b>	<b>35</b>
Section 6.2.1.	Introduction .....	35
Section 6.2.2.	Manual Over-Ride Operation .....	35
Section 6.2.3.	Automatic Operation .....	36
Section 6.2.4.	Automatic Operation (Beta Option).....	37
<b>CHAPTER 7.</b>	<b>DYNAMIC BALANCE .....</b>	<b>39</b>
<b>CHAPTER 8.</b>	<b>SET-UP OF PROPELLER PITCH STOPS .....</b>	<b>42</b>
<b>Part 8.1.</b>	<b>Propeller Pitch and Blade Angle.....</b>	<b>42</b>
<b>Part 8.2.</b>	<b>Fixed Pitch Stops.....</b>	<b>42</b>
<b>Part 8.3.</b>	<b>Adjustable Pitch Stops – Guidelines for Setting.....</b>	<b>42</b>
Section 8.3.1.	Introduction .....	42
Section 8.3.2.	Ground Static Tests .....	43
Section 8.3.3.	Flight Tests to Verify Safety of Flight .....	44
Section 8.3.4.	In-Flight Performance Verification.....	45
<b>Part 8.4.</b>	<b>Adjustable Pitch Stops – Method of Adjustment .....</b>	<b>45</b>
Section 8.4.1.	Introduction .....	45
Section 8.4.2.	Identification of Adjustable Pitch Stops.....	45
Section 8.4.3.	Method of Adjustment.....	48
Section 8.4.4.	Techniques to Assist Adjustment to Desired Pitch Setting.....	50
<b>CHAPTER 9.</b>	<b>OPERATION OF AC200 SMARTPITCH CONTROLLER.....</b>	<b>51</b>
<b>Part 9.1.</b>	<b>Controls and Functions.....</b>	<b>51</b>
Section 9.1.1.	Introduction .....	51
Section 9.1.2.	Automatic/Manual Selector .....	52
Section 9.1.3.	Propeller Control Selector.....	52
Section 9.1.4.	Engage Switch (option).....	55
Section 9.1.5.	Manual Control Switch .....	55
<b>Part 9.2.</b>	<b>Indications .....</b>	<b>56</b>
<b>Part 9.3.</b>	<b>Failure Modes.....</b>	<b>57</b>
Section 9.3.1.	Introduction .....	57
Section 9.3.2.	Loss of Power .....	57
Section 9.3.3.	Open circuit.....	58
Section 9.3.4.	Over-Current .....	58
Section 9.3.5.	Short Circuit .....	58
Section 9.3.6.	Controller Failure .....	59
Section 9.3.7.	Controller Software Fault .....	59
Section 9.3.8.	Loss of Speed Signal .....	59
Section 9.3.9.	Failure of Manual Control Switch .....	59
Section 9.3.10.	Failure of Adjustable Pitch Stops Microswitches.....	60
Section 9.3.11.	Failure of Beta function stops. ....	60
<b>CHAPTER 10.</b>	<b>OPERATING INSTRUCTIONS .....</b>	<b>62</b>
<b>Part 10.1.</b>	<b>Introduction and Applicability .....</b>	<b>62</b>
<b>Part 10.2.</b>	<b>General Handling .....</b>	<b>62</b>
Section 10.2.1.	Introduction .....	62

Section 10.2.2.	Automatic Operation .....	62
Section 10.2.3.	Manual Over-Ride.....	63
<b>Part 10.3.</b>	<b>Functional Checks and Procedures .....</b>	<b>63</b>
Section 10.3.1.	Introduction .....	63
Section 10.3.2.	Pre-Start Check (Feathering).....	63
Section 10.3.3.	Starting .....	64
Section 10.3.4.	Engine Run-Up and Pre-Take-Off Check.....	64
<b>Part 10.4.</b>	<b>Flight Operations .....</b>	<b>65</b>
Section 10.4.1.	Introduction .....	65
Section 10.4.2.	Taxi.....	65
Section 10.4.3.	Take-Off.....	65
Section 10.4.4.	Climb.....	65
Section 10.4.5.	Cruise .....	65
Section 10.4.6.	Hold Speed Governing Mode.....	65
Section 10.4.7.	Feathering (Option).....	66
Section 10.4.8.	Before Landing Check .....	67
Section 10.4.9.	Landing.....	67
Section 10.4.10.	Beta (Option) .....	68
Section 10.4.11.	Flight in Special Conditions.....	69
<b>Part 10.5.</b>	<b>Emergency Operation.....</b>	<b>69</b>
<b>CHAPTER 11.</b>	<b>INSPECTION, MAINTENANCE AND REPAIR.....</b>	<b>71</b>
<b>Part 11.1.</b>	<b>Introduction .....</b>	<b>71</b>
<b>Part 11.2.</b>	<b>Inspection .....</b>	<b>71</b>
Section 11.2.1.	Pre-Flight Inspection.....	71
Section 11.2.2.	Periodic Inspection and Lubrication (At First 25 Hours, First 50 Hours, First 100 Hours and Subsequently at 100 Hour Intervals)....	72
<b>Part 11.3.</b>	<b>Maintenance .....</b>	<b>74</b>
Section 11.3.1.	Replacement of Leading Edge Erosion Protection Strip .....	74
Section 11.3.2.	Replacement of Slip-Ring Brushes.....	74
<b>Part 11.4.</b>	<b>Repair.....</b>	<b>75</b>
<b>Part 11.5.</b>	<b>Removal .....</b>	<b>76</b>
<b>Part 11.6.</b>	<b>Overhaul .....</b>	<b>77</b>
Section 11.6.1.	Overhaul Instructions .....	78
Section 11.6.2.	Overhaul tooling.....	78
Section 11.6.3.	Training required.....	78
Section 11.6.4.	Overhaul Inspections .....	78
Section 11.6.5.	Overhaul sequence.....	78
Section 11.6.6.	Testing Requirements.....	78
Section 11.6.7.	Mandatory Replacement Intervals .....	78
<b>Part 11.7.</b>	<b>Shipping and Storage.....</b>	<b>78</b>
<b>ANNEX A.</b>	<b>PRINCIPAL DIMENSIONS OF PROPELLER INSTALLATIONS .....</b>	<b>79</b>
<b>ANNEX B.</b>	<b>AC200 SMARTPITCH CONTROLLER CABLES, WIRES AND CONNECTOR PINS.....</b>	<b>83</b>
<b>ANNEX C.</b>	<b>PROPELLER HUB AND SENSOR/BRUSH ASSEMBLY WIRING .....</b>	<b>84</b>
<b>ANNEX D.</b>	<b>INSTRUMENT PANEL CUTOUT FOR AC200 SMARTPITCH CONTROLLER .....</b>	<b>85</b>

## LIST OF FIGURES

Figure 1.	General Layout of Propeller Hub Assembly (AP332 shown) .....	8
Figure 2.	General Layout of Blade Assembly on 3 series (arrangement of seals may differ on production examples) .....	9
Figure 3.	Illustration of AC200 SmartPitch Controller (Feathering version shown).....	10
Figure 4.	Recommended Engine Propeller combinations.....	13
Figure 5.	Weight and MOI Chart .....	13
Figure 6.	Airmaster Manufactured Flange Installed on Jabiru Engine (example shows standard flange without prop extension) .....	18
Figure 7.	Mounting of Propeller Hub to Propeller Flange.....	20
Figure 8.	Blade Assembly (AP332 shown).....	22
Figure 9.	Blade Assembly Mounted into Propeller Hub (AP332 shown) .....	23
Figure 10.	AC200 SmartPitch Controller Cable Installation and Rear View of Control Unit ....	26
Figure 11.	AC200 Control Unit Installation Dimensions .....	27
Figure 12.	Manual Control Switch Installation Dimensions.....	28
Figure 13.	Illustration of the Sensor/Brush Assembly Mounted on a Rotax Engine (AP332 shown) .....	29
Figure 14.	Illustration of the Sensor/Brush Assembly Mounted on a Jabiru Engine (example shows standard flange without prop extension/AP332) .....	30
Figure 15.	Sample Balance Weight Installation on 212mm(8.3in) Spinner Back-Plate.....	40
Figure 16.	Sample Balance Weight Installation on 228mm(9in) Spinner Back-Plate.....	40
Figure 17.	Sample Balance Weight Installation on 262mm(10.3in) and 285mm(11.2in) Spinner Back-Plates .....	41
Figure 18.	Location of Adjustable Pitch Stops on 3 bladed Propeller Hub Assembly (AP332 shown) .....	46
Figure 19.	Location of Adjustable Pitch Stops on 2-bladed Propeller Hub Assembly (AP420 shown) .....	47
Figure 20.	Adjustment of Pitch Feedback Cam (AP332 shown).....	49
Figure 21.	Controls of AC200 SmartPitch Controller (Feathering version shown) .....	51
Figure 22.	Blade Assembly (AP332 shown).....	73

## CHAPTER 1. INTRODUCTION

### Part 1.1. Introduction

Thank you for selecting an Airmaster propeller. Airmaster propellers are designed and manufactured to enhance the performance of your light aircraft.

The 3 & 4 series propellers are multi-functional, variable pitch propellers designed for use on engines up to 120hp (90hp when fitted to direct drive engines). The propellers are controlled with the AC200 'SmartPitch' constant speed controller. Airmaster Propellers Ltd ('the manufacturer') currently approve the 3 & 4 series propeller systems for installation on the following types of aircraft engines:

- Rotax 912, 912S and 914
- Jabiru 2200 and 3300

Note: For use on other engine types, consult the manufacturer.

### Part 1.2. Use of This Manual

This manual contains all the information on the Airmaster propeller required by operators of the propeller. The manual should be referred to, and read carefully, by owners, pilots and maintenance personnel ('operators'). The manual covers the following subjects:

- Installation.
- Set-Up.
- Operation.
- Maintenance.

Responsibility for correct installation, set-up, operation and maintenance of the propeller belongs to the operator. Failure to carefully read and follow the information in this manual may result in poor propeller performance, unsafe propeller operation, and may also result in the warranty on the propeller becoming void.

### Part 1.3. Warnings, Cautions and Notes

Please pay attention to the following types of content throughout this document emphasizing particular information:

**Warning:** If you choose not to follow a WARNING, possible consequences may include personal injury or death.

**Caution:** If you choose not to follow a CAUTION, consequences may include damage to equipment and voiding of warranty

Note: A note provides advice based on our experience that is intended to make the associated task/s easier to accomplish

## CHAPTER 2. PHYSICAL DESCRIPTION

### Part 2.1. Description of AP3xx & AP4xx Series Propellers

The hub of the propeller is a single high strength component, either manufactured from directionally solidified cast aluminium and machined to final dimensions, or a machined from solid billet material. Other components within the propeller are machined from a variety of engineering materials.

Airmaster variable pitch propellers have an electrically operated pitch change mechanism. This system incorporates a control system that passes electric power to the propeller via a sensor/brush assembly mounted on the aircraft engine and a specially constructed slip-ring assembly mounted on the spinner back-plate. The pitch change motor is an electric servomotor assembly incorporating a planetary gearbox, which operates a pitch change mechanism.

The pitch change mechanism incorporates a precision-engineered drive screw mechanism that controls the position of a pitch change slide. The pitch change slide is moved along the axis of the propeller hub and acts upon a cam-follower attached to the base of each propeller blade assembly. Movement of the pitch change mechanism therefore causes a corresponding change in blade angle on each propeller blade.

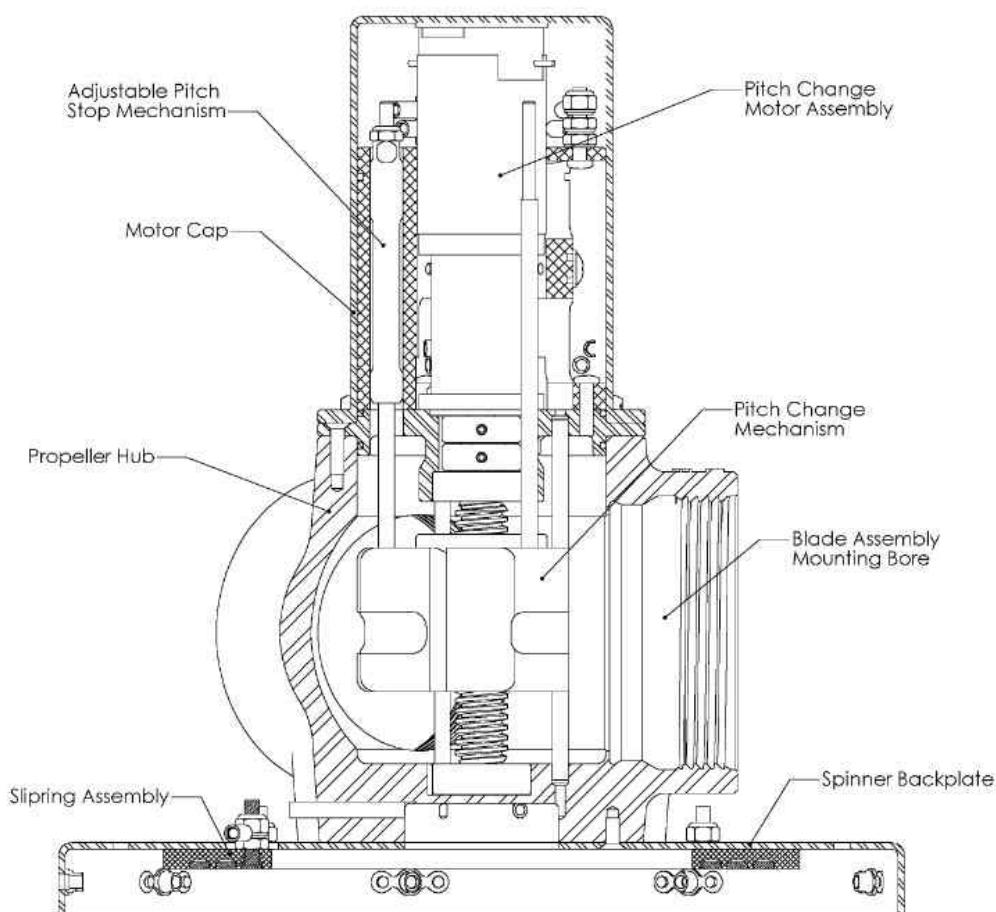

**Figure 1. General Layout of Propeller Hub Assembly (AP332 shown)**



The pitch limits and pitch range of the propeller are controlled by a robust system of fixed and adjustable pitch stops. The fixed stops provide physical limits to the movement of the pitch change mechanism. The adjustable pitch stops are each formed by a microswitch that controls the flow of electric power to the pitch change motor. These microswitches are actuated by adjustable pitch feedback cams, which are connected to the pitch change mechanism. The operator can easily and precisely adjust each of the adjustable pitch stops to set up the propeller for safe operation on any particular aircraft.

The pitch change mechanism and controller design of the Airmaster propeller allows the possibility of additional features such as feathering and reverse. The 3 & 4 series propellers have been designed to be fully feathering, making them ideally suited to motor glider applications.

Airmaster propellers incorporate a blade retention system that allows the blade assemblies to be simply removed from the hub, and then replaced with complete accuracy of set-up by the operator. This feature facilitates shipment, servicing and maintenance of the propeller system.

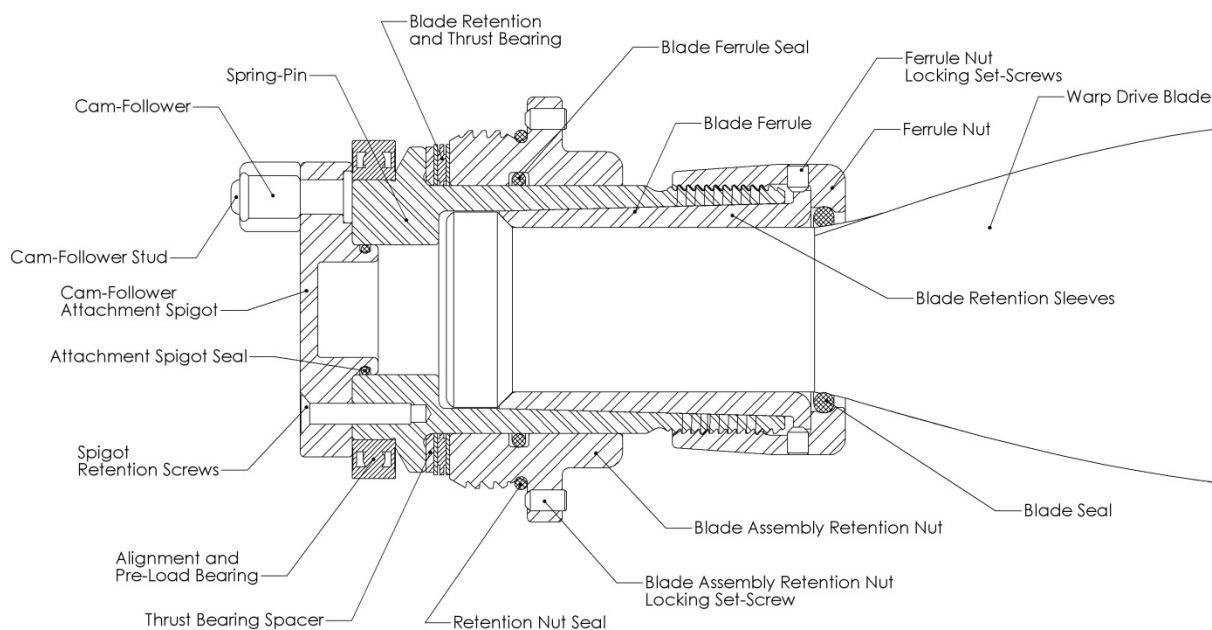

**Figure 2. General Layout of Blade Assembly on 3 series  
(arrangement of seals may differ on production examples)**

The propeller blade is retained in a ferrule component in the blade retention system by a system of tapered sleeves acting as a collet, which are held in place by a special ferrule nut. The blade assembly incorporates the required bearings and retention devices. The blade assembly is retained in the propeller hub by means of another special nut, the blade assembly retention nut, which is threaded with a high strength buttress thread.

## **Part 2.2. Description of AC200 SmartPitch Controller**

Airmaster propellers are controlled by the Airmaster AC200 SmartPitch constant speed controller. This controller has been exclusively designed to work with Airmaster propellers and delivers true constant speed operation. Constant speed operation is where a governor adjusts the blade angle or pitch to deliver the constant engine/propeller speed that has been selected by the pilot (ie if the speed is too high, the pitch is increased; if the speed is too low, the pitch is decreased).

The AC200 SmartPitch controller is a solid-state microprocessor based device that employs electronic governing. To monitor the propeller speed the controller uses a solid-state magnetic sensor incorporated in the sensor/brush assembly, which is mounted on the aircraft engine. The sensor detects the passing of a magnet integrated into the propeller's slip-ring assembly.

The electronic governor compares the current propeller speed with that selected by the pilot. The electronic governor then uses a digital control loop to determine the controller response. The non-linear response of the control loop is controlled by various parameters set in the controller's software. (These control parameters determine how the response of the controller is affected by the size of the speed error, or the whether the error is decreasing or increasing.) Feedback to the propeller is by electric power delivered to the pitch-change motor via solid-state power drivers.

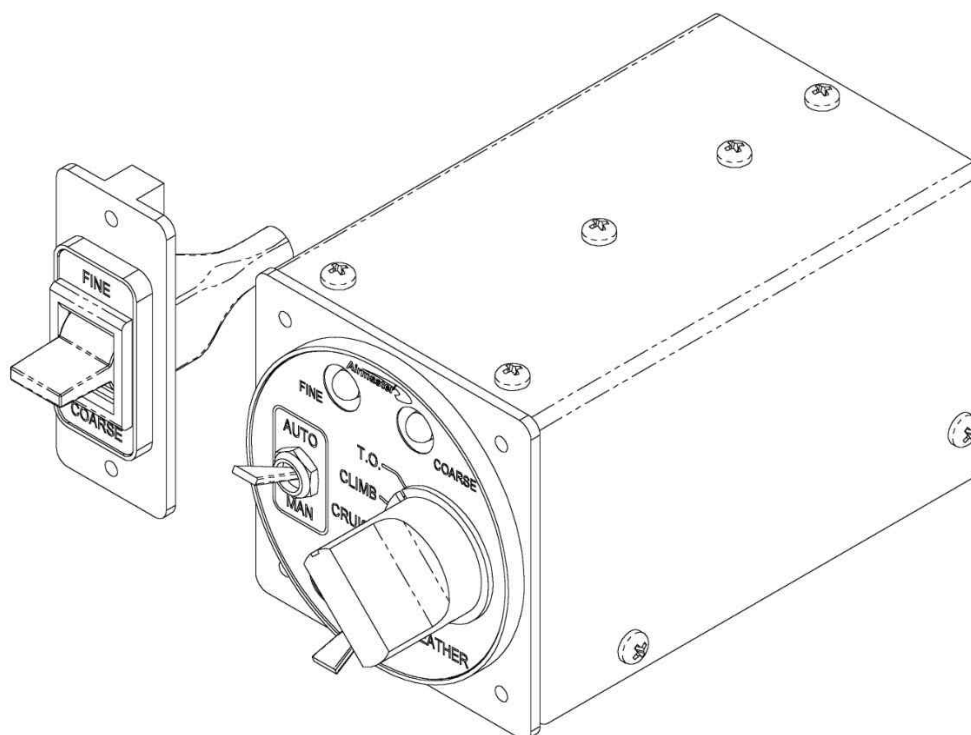

**Figure 3. Illustration of AC200 SmartPitch Controller (Feathering version shown)**

The AC200 SmartPitch controller mounts in the aircraft's instrument panel using a standard 2-1/4in instrument cut-outs. The ergonomically designed pilot interface or control panel of the controller incorporates a distinctive blue propeller control selector and indication lights. The propeller control selector is a rotary switch, which the pilot uses to select the desired governing speed, and to switch between various modes of operation. These modes incorporate pre-set and hold governing speeds, and a feather function. The three indication lights provide visual feedback of the propeller's operational status to the pilot. A manual over-ride option is also provided on the controller.

Mounted separately to the controller is a manual control switch, which is used to control the propeller pitch or blade angle directly when manual over-ride is enabled, or to set the governed engine/propeller speed when hold mode is selected.

The AC200 SmartPitch controller can be programmed by using a personal computer with a RS232C serial connection. This enables the pre-set speeds and other operational parameters to be customised for any particular application.

## Part 2.3. Identification

Airmaster products are uniquely identified by a combination of letters and numbers

### Section 2.3.1. Hubs

The hubs are marked in the following way:

- a. Manufacturer – Letters ‘AP’ embossed on top of port 1 denotes “Airmaster”
- b. Product – Letter ‘AP’ embossed on top of port 1 denotes product type “Propeller”
- c. Model – Three numbers following ‘AP’ define
  - i. 1st letter – propeller series
  - ii. 2<sup>nd</sup> letter – number of ports
  - iii. 3<sup>rd</sup> letter – model within a series
- d. Serial number- three letters stamped at the base of the hub opposite port 1.
- e. Port ID – The number of each port is embossed at the top of each port
- f. Propeller diameter – If required the propeller diameter can be stamped at the base of the hub on the opposite side from the serial number. The units of diameter are inches.

### Section 2.3.2. Controllers.

The controllers are marked in the following way on the rear of the case:

- a. Manufacturer – Letters ‘AC’ denotes Airmaster Controller
- b. Model – Three numbers following ‘AC’ define controller series
- c. Serial number – three numbers printed on the rear side of the case
- d. Software version – three numbers following ‘SW’ denote
  - i. 1<sup>st</sup> number - software series
  - ii. 2<sup>nd</sup>/3<sup>rd</sup> number - revision

## CHAPTER 3. SPECIFICATIONS

### Part 3.1. General Specifications

	AP332*	AP420*	AP430*
Power Capacity:			
Reduction gear driven, or 6-cylinder direct drive engines:	115hp (89.5kW).	120hp (89.5kW).	150hp (89.5kW).
4-cylinder direct drive engines:	n/a	90hp (67.0kW).	120hp (67.0kW).
6-cylinder direct drive engines	n/a	120hp (89.5kW).	150hp (89.5kW).
Maximum Speed:	2600 rpm.	3300 rpm.	3300 rpm.
Maximum Diameter:	72in (183cm).	72in (183cm).	75in (183cm).
Weight (approximate, data shown for 68in diameter and 10inch spinner):			
On engine weight (hub, blades, spinner, sensor/brush block):	26lb (11.8kg).	20.5 lb (9.3 kg).	26 lb (11.8 kg).
In cockpit weight (control unit, manual switch and cables):	0.6lb (0.28kg)	0.6lb (0.28kg).	0.6lb (0.28kg).
Total Weight:	26.6lb (12.1kg).	21.1 lb (9.6 kg).	26.6 lb (12.1 kg).
Rotational Moment of Inertia ( data shown for 68in diameter and 9inch spinner):	~0.6 kgm <sup>2</sup> .	~0.4 kgm <sup>2</sup> .	~0.6 kgm <sup>2</sup> .
To Fit Prop Flanges:	Six-hole pattern at 4in (101.6mm) PCD, with maximum OD of 5in (127mm). This includes: 101.6mm PCD Rotax Flange (PN 837 28# series). Jabiru 2200 Flange (125mm OD) (PN 4525064 (standard) or PN 4610074 (2-inch extension)). Alternative flange supplied by Airmaster.		
Power Requirements:			
Voltage Supply:	10V - 16V DC (12V DC Nominal).		
Current Supply:	Stand-by: 0.1A. Changing pitch: 0.5 – 2.0 A.		
Circuit Breaker Requirement:	3A Circuit Breaker.		
Programming:	Via RS232C to PC.		

Note: \* Approximate data only. Actual figures depend on final configuration of propeller.

### Part 3.2. Engine Propeller combinations

The following chart can be used as a guide for propeller and engine combinations. Other combinations are possible; please contact Airmaster for advice on this.

	Rotax 912	Rotax 912S	Rotax912iS	Rotax 914	Jabiru 2200	Jabiru 3300	
AP332AP*-WDN63L	*	*	*	*			
AP332AP*-WDN68L		*	*	*			
AP332AP*-WDT68L	*	*	*	*			
AP332CT*-WDN64R	*	*	*	*			
AP332CT*-WDT64R	*	*	*	*			
AP332CT*-WDN68R		*	*	*			
AP332CT*-WDT68R	*	*	*	*			
AP332CT*-WDT70R		*	*	*			
AP332CT*-WDT72R		*	*	*			
AP332CT*-BY68R	*	*	*	*			
AP332CT*-BY72R		*	*	*			
AP420CTF*-SNR62HN					*		
AP420CT*-SNR64ZN						*	
AP420CT*-SNR68EN	*	*	*	*			
AP420CT*-SNR70EN	*	*	*	*			
AP430CT*-KV64R	*						
AP430CT*-KV68R	*	*	*	*			
AP430CT*-KV71R		*	*	*			
AP430CT*-KV75R		*	*	*			
AP430AP*-SNL68CN							
AP430CT*-SNR68CN	*	*	*	*			
AP430CT*-WW70WB		*	*	*			

Figure 4. Recommended Engine Propeller combinations

### Part 3.3. Configuration Specifications

The following chart gives configuration specific specifications.

Propeller Configuration	Power (Hp max)		Speed (RPM max)	Weight		MOI Kgm^2
	HP	kW		kg	lbs	
AP332*-WDT68*—R9.0	115	85	2600	10.5	23.1	0.59

Figure 5. Configuration Specifications

## CHAPTER 4. MATERIALS REQUIRED

### Section 4.1.1. Introduction

Parts of this manual call for certain materials to be used during the assembly, installation and maintenance of the propeller. Suitable products for use are listed here.

### Section 4.1.2. Grease

At manufacture the propeller is lubricated with Shell Aviation grease, 'AeroShell Grease 22' (ASG22). This grease complies with specification MIL-G-81322E 'Grease, Aircraft, General Purpose, Wide Temperature Range' (UK equivalent; DEF STAN 91-52/1). Greases compatible with this specification include:

- |                           |                      |
|---------------------------|----------------------|
| • Shell Aviation grease   | AeroShell Grease 22. |
| • Royal Lubricants grease | Royco22CF.           |
| • Castrol grease          | Braycote 622.        |
| • Exxon grease            | Unitemp 500.         |
| • Mobil grease            | Mobilgrease 28.      |

It is recommended that the propeller be lubricated with AeroShell Grease 22, or grease manufactured to the same specification. However, where such greases are unavailable, alternatives may be acceptable. A visit to a local aircraft maintenance facility should allow an operator to source a commonly available general-purpose aircraft grease. When selecting an alternative grease, operators should assess the grease for suitability.

The requirements for grease lubrication of the propeller are similar to that found in other aircraft applications. Operators may find that a single grease is suitable for lubrication of the propeller and other locations on their aircraft. In particular, grease selected for lubrication of the propeller should have the following characteristics:

- Suitable for rolling bearings, and sliding applications such as screw-jacks.
- Suitable for high bearing loads.
- Suitable for low temperature use.
- Have good retention characteristics.
- Have good resistance to water wash-out.
- Provide corrosion protection.
- Suitable for use in contact with common engineering plastics and seals.

Usually it will be found that the most general-purpose aircraft greases are compatible with each other. However compatibility cannot be guaranteed with different greases. It is recommended that

when different grease is to be used, the majority of existing grease be removed from the propeller mechanism. Simply wipe the excess grease from parts of the propeller; do not use a solvent.

#### Section 4.1.3. Jointing Compound

In order to prevent corrosion, and facilitate future disassembly, some components should be assembled with an anti-corrosive jointing compound. Such compounds are sometimes called anti-fret compounds or anti-seize compounds. Suitable compounds include:

- PRC-DeSoto CA1000.
- PRC-DeSoto JC5A.
- Kluber Lubrication Kluberpaste 46 MR 401.
- Llewelyn Ryland Ltd Duralac.
- Loctite Zinc Anti-Seize.

#### Section 4.1.4. Thread-Locking Compound

During assembly of the propeller some fasteners require installation with thread-locking compounds to provide enhanced security. Loctite products are recommended, although equivalent products may be used. Depending on the strength required, the following grades should be used:

- Low strength Loctite 222.
- Medium strength Loctite 243.
- High strength Loctite 262.

## CHAPTER 5. INSTALLATION

### Part 5.1. Unpacking the Propeller

**Caution:** The three sets of bolts, washers and spacers that hold the propeller hub to the plywood base in the packaging container are for shipping and storage purposes only. These bolts, washers and spacers are not to be used in any form for propeller assembly, installation or operation.

**Caution:** Always place propeller hub assembly carefully on a soft and clean surface in order not to damage the spinner back-plate and the slip-ring assembly.

**Note:** There are two different configurations of spinner front support. If the support is mounted to the motor cap by a screw thread, leave front support in place. If the front support is a loose part, remove and retain front support with spinner.

- a. Carefully remove the propeller hub assembly, blade assemblies, other components and documentation from the packaging containers.
- b. Remove the spinner and spinner front support (if applicable) from the propeller hub in preparation for fitting the propeller to the engine.

**Note:** The original packaging containers and materials should be used whenever the propeller is to be shipped or stored. It is recommended that all original packaging be retained for future occasions requiring shipping or storage.

### Part 5.2. Fit of Propeller with Engine Installation and Cowling Geometry

The 3 & 4 series propellers come fitted with a spinner. The following standard spinner sizes are available as options to fit most common installations:

- 212mm (8.3in).
- 228mm (9in).
- 262mm (10.3in).
- 285mm (11.2in).
- 310mm (12.2in).

A good fit between the propeller spinner and the aircraft engine cowling is important for aerodynamic reasons and visual appearance. Diagrams showing the principal dimensions with respect to the engine propeller flange of the propeller and the spinner installations are at ANNEX A. Principal Dimensions of Propeller Installations.



## Part 5.3. Preparation of Engine Propeller Flange

### Section 5.3.1. Introduction

The 3 & 4 series propellers are attached to the engine propeller flange by bolts that pass through the flange into the propeller hub. The propeller is designed to fit flanges with six holes on a 4-inch PCD pattern. The following flanges utilise this pattern and may be used with this propeller (For any other flange pattern a special adapter will have to be used.):

- ARP502 style.
- 101.6mm Rotax Flange (PN 837 28# series).

The manufacturer supplies alternative engine propeller flange assemblies to be used with Jabiru engines. These flanges are similar to the Jabiru supplied items, with improved strength. See Section 5.3.3, Installation of Airmaster Manufactured Jabiru Engine Propeller Flange, in this chapter.

**Note:** Jabiru 2200 engines are normally supplied with flanges that have the same hole pattern as the propeller (PN 4525064 (standard) or 4610074 (2-inch extension)). However, as detailed above, the supplied alternative flange should be used.

**Note:** Jabiru 3300 engines are normally supplied with different flanges designed to the SAE1 pattern, which do not fit Airmaster 3 & 4 series propellers. The supplied alternative flange should be used.

**Note:** Jabiru flanges are also available in extensions longer than 2 inches. However, this propeller should not be used with Jabiru extension flanges longer than 2 inches.

### Section 5.3.2. General

Ensure that engine propeller flange is clean, and free of nicks and burrs. If aircraft engine has been involved in a previous incident and the existing propeller was damaged, have the propeller flange checked by an engine maintenance facility. The run-out of the centre bush should be not more than 0.125mm(0.005in) and the axial run-out of the propeller flange forward face on outer diameter should be not more than 0.075mm(0.003in).

**Note:** A new engine can be damaged in shipment and/or installation. Do not assume that the propeller flange is undamaged. Inspect for any evidence of the propeller flange being damaged, and check run-out if any damage is suspected.

### Section 5.3.3. Installation of Airmaster Manufactured Jabiru Engine Propeller Flange

The manufacturer supplies alternative engine propeller flange assemblies to be used with Jabiru engines. These flanges are similar to the Jabiru supplied items, with improved strength. The flanges attach to the engine crankshaft in a similar manner to the Jabiru supplied items, but with a spacer between the heads of the cap-screws and the flange itself. Two flanges are available:

- Jabiru Engine Propeller Flange, Standard (AP-P-0209).
- Jabiru Engine Propeller Flange, 50mm (2in) Extension (AP-P-0210).

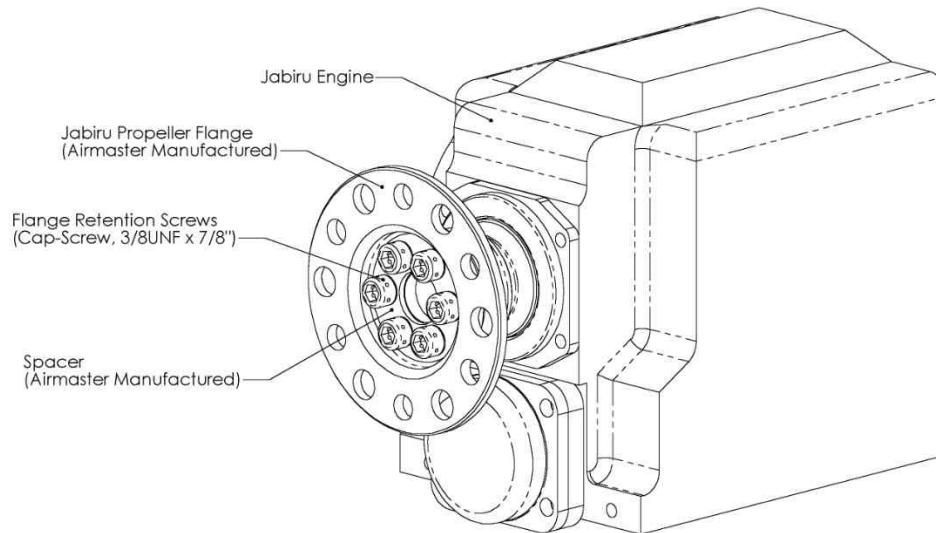

**Figure 6. Airmaster Manufactured Flange Installed on Jabiru Engine (example shows standard flange without prop extension)**

Each of the two flanges should be installed in a different manner as detailed below.

**Fitting Jabiru Engine Propeller Flange, Standard (AP-P-0209).** The flange should be fitted using the following procedure:

- a. Remove existing flange.
- b. Ensure that face of engine crankshaft is clean and free from damage.
- c. Fit alternative flange to engine crankshaft and fit spacer in recess of flange. Ensure that chamfered edge of spacer faces the flange.
- d. Fit cap-screws 3/8UNF x 7/8in with high strength thread-locking compound such as Loctite 262.

**Caution:** Ensure that surfaces are free from oils and contaminants to ensure performance of the thread-locking compound.

**Caution:** Do not use the cap-screws supplied by Jabiru. Due to the spacer used in the Airmaster design, longer cap-screws are required.

- e. Torque cap-screws to 40Nm(30ftlb).
- f. Lock-wire cap-screws with 0.032in lock-wire.

**Fitting Jabiru Engine Propeller Flange, 50mm(2in) Extension (AP-P-0210).** The 3/8UNF cap-screws supplied to attach the Airmaster manufactured Jabiru engine propeller flange to the Jabiru engine are supplied with Nord-Lock<sup>®</sup> washers. These washers secure a fastener from loosening due to vibration and dynamic loads. They work by requiring a higher torque to un-tighten than is required to tighten them. The washers are supplied a pre-assembled pairs, and should be used in these pairs. The flange should be fitted using the following procedure:

- a. Remove existing flange.
- b. Ensure that face of engine crankshaft is clean and free from damage.
- c. Fit alternative flange to engine crankshaft and fit spacer in recess of flange. Ensure that chamfered edge of spacer faces the flange.
- d. Fit cap-screws 3/8UNF x 1in with supplied 3/8in Nord-Lock<sup>®</sup> washers. Lightly lubricate the threads of the cap-screws with a film of grease.

**Caution:** Do not use the cap-screws supplied by Jabiru. Due to the spacer and the washers used in the Airmaster design, longer cap-screws are required.

**Caution:** Ensure that the washers are paired so that the cam surfaces face each other. Do not use only one half of the washer pairs. Do not use any other washer in combination with the Nord-Lock<sup>®</sup> washer pairs.

- e. Torque cap-screws to 50Nm(37ftlb).

The Nord-Lock<sup>®</sup> washers may only be reused once. If reusing the washers, separate the washer pairs, and lubricate the cam surfaces with a film of grease before re-assembly.

#### Section 5.3.4. Drive Lugs

The propeller flange must be fitted with drive lugs to locate the propeller and transmit power to it.

**Removal of Existing Drive Lugs.** The drive lugs used with other propellers cannot be used with the 3 & 4 series propellers and have to be replaced. They are a press fit, and should not be removed by hammering out. An extracting tool is supplied that may be used to remove shear-bushes from propeller flanges. A variety of bolts, nuts, washers and spacers are supplied with the extracting tool to match with possible configurations of existing bushes.

**Installation of Airmaster Drive Lugs.** The drive lugs supplied with propeller should be installed with jointing compound, and by using a reverse process to the above extraction. The following drive lugs are available:

- Rotax Drive Lug (AP-P-0070).
- Jabiru Drive Lug (AP-P-0059).

### Part 5.4. Installation of Propeller Hub on Engine

The propeller comes as a complete assembly with the spinner back-plate fitted to the hub. The spinner should be removed from the hub for the following assembly procedure.

**Note:** Always place propeller hub assembly carefully on a soft and clean surface in order not to damage the spinner back-plate and the slip-ring assembly.

**Note:** The instructions in this part assume that the propeller hub will be installed on the aircraft before the propeller blades are assembled to the hub. This is the recommended procedure, however in some cases operators may find it easier to fully assemble the propeller before the hub is installed on the aircraft.

**Note:** Operators may find it easier to fit the sensor-brush assembly to the engine before installing the propeller hub (particularly in the case of the Jabiru installation). The hub and the sensor/brush assembly may be installed in either order. See Section 5.7.4, Sensor/Brush Assembly, in this chapter.

Prior to installation, the propeller should also be inspected for shipping damage. In particular the spinner back-plate attached to the rear of the hub should be smooth and free from damage.

The following procedure for installing the propeller to the engine propeller flange should be followed:

- a. Clean engine propeller flange.
- b. Clean rear face of hub-assembly.
- c. Coat drive-lugs with a light film of jointing compound.

**Caution:** Ensure that jointing compound does not get on flat face of flange or spinner back-plate. Friction between these two components is important for transmission of power to the propeller.

- d. Carefully slide hub assembly over drive-lugs and push into place.

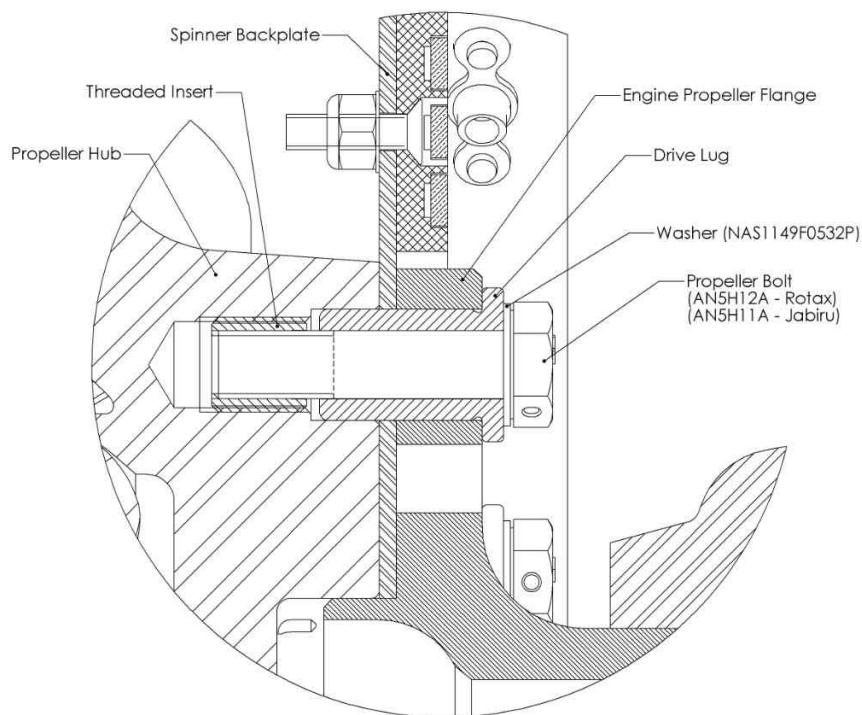

**Figure 7. Mounting of Propeller Hub to Propeller Flange**

- e. Install six 5/16in AN bolts with washers (all supplied), and lightly tighten by hand. The following fasteners should be used as applicable:
  - Bolts for Rotax Flange.      AN5H12A.      (AP-P-0180).
  - Bolts for Jabiru Flange.      AN5H11A.      (AP-P-0173).

Note: The washers are important to prevent the bolt thread binding in the threaded insert.

f. Torque in increments, and by alternately tightening opposite pairs of bolts, to 20Nm(15ftlb).

**Caution:** Ensure that the propeller bolts are not over tightened. This may cause a risk of the insert being stripped from the hole. Even a torque of 14Nm(10ftlb) is sufficient to ensure an adequate pre-load on the propeller bolts.

g. Lock-wire bolts with 0.032in lock-wire.

#### Section 5.4.2. Use of Nord-Lock Washers

The AN5 (5/16UNF) bolts supplied to attach an Airmaster propeller to a Rotax engine are sometimes now supplied with Nord-Lock<sup>®</sup> washers. These washers secure a fastener from loosening due to vibration and dynamic loads. They work by requiring a higher torque to un-tighten than is required to tighten them.

Note: Where the extension is attached to the Rotax flange using the Rotax threaded drive lugs, M8 x 40mm bolts are supplied.

5/16in Nord-Lock<sup>®</sup> washers (NL8) are supplied with the AN5 bolts. The washers are supplied a pre-assembled pairs, and should be used in these pairs.

**Caution:** Ensure that the washers are paired so that the cam surfaces face each other. Do not use only one half of the washer pairs. Do not use any other washer in combination with the Nord-Lock<sup>®</sup> washer pairs.

When fitting the propeller (and spacer) to the engine propeller flange, fit the AN5 bolts with the Nord-Lock<sup>®</sup> washers. Do not use thread-locking compound.

Torque the AN5 bolts to 25Nm(18ftlb). This torque is higher than the torque detailed for plain washers.

After fitting the bolts, there is no requirement to lock-wire the bolts.

The Nord-Lock<sup>®</sup> washers may only reused once. If reusing the washers, separate the washer pairs, and lubricate the cam surfaces with a film of grease before re-assembly.

## Part 5.5. Assembly of Blades to Propeller Hub

Note: The instructions in this part assume that the propeller hub is already installed on the aircraft. This is the recommended procedure, however in some cases operators may find it easier to assemble the propeller before installing it on the aircraft.

### Section 5.5.1. Introduction

Prior to assembly, all parts should be inspected for shipping damage. In particular the hub should be inspected for nicks and burrs at each propeller bore, and the thread on the blade nuts should be inspected for any sign of damage.

### Section 5.5.2. Assembly Procedure

The following procedure should be followed to assemble the propeller:

- a. Ensure all components are clean and free from damage. If internal threads of propeller hub and threads of blade assembly retention nut require cleaning a cloth and a toothbrush may be used.
- b. Lubricate the blade assembly mounting bores and internal threads of the propeller hub with grease in accordance with Airmaster Service Letter AP-D-009

**Note:** The manufacturer will have already lubricated the pitch change drive spindle and nut inside the hub. Ensure that these items are adequately lubricated with grease.

- c. Select a blade. Each blade assembly is marked with a number that corresponds to a matching bore on the propeller hub. The number is stamped on the outer edge of the cam-follower attachment spigot near the cam-follower.

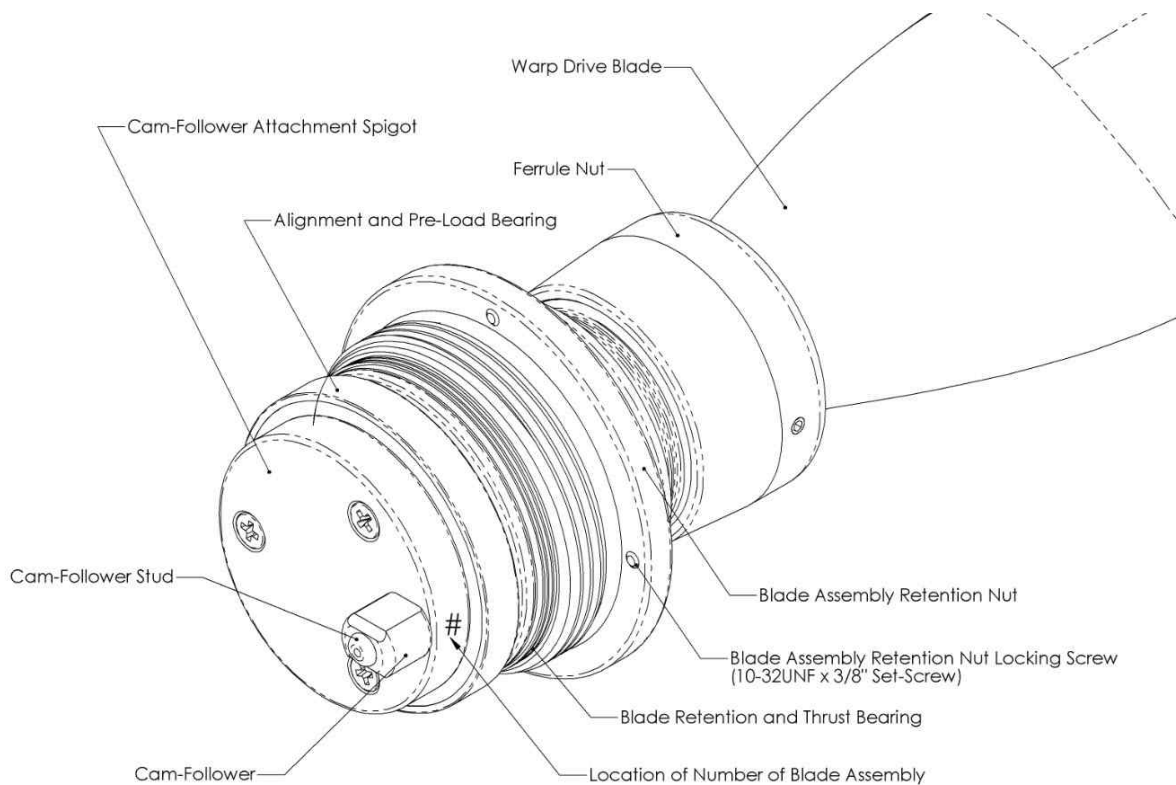
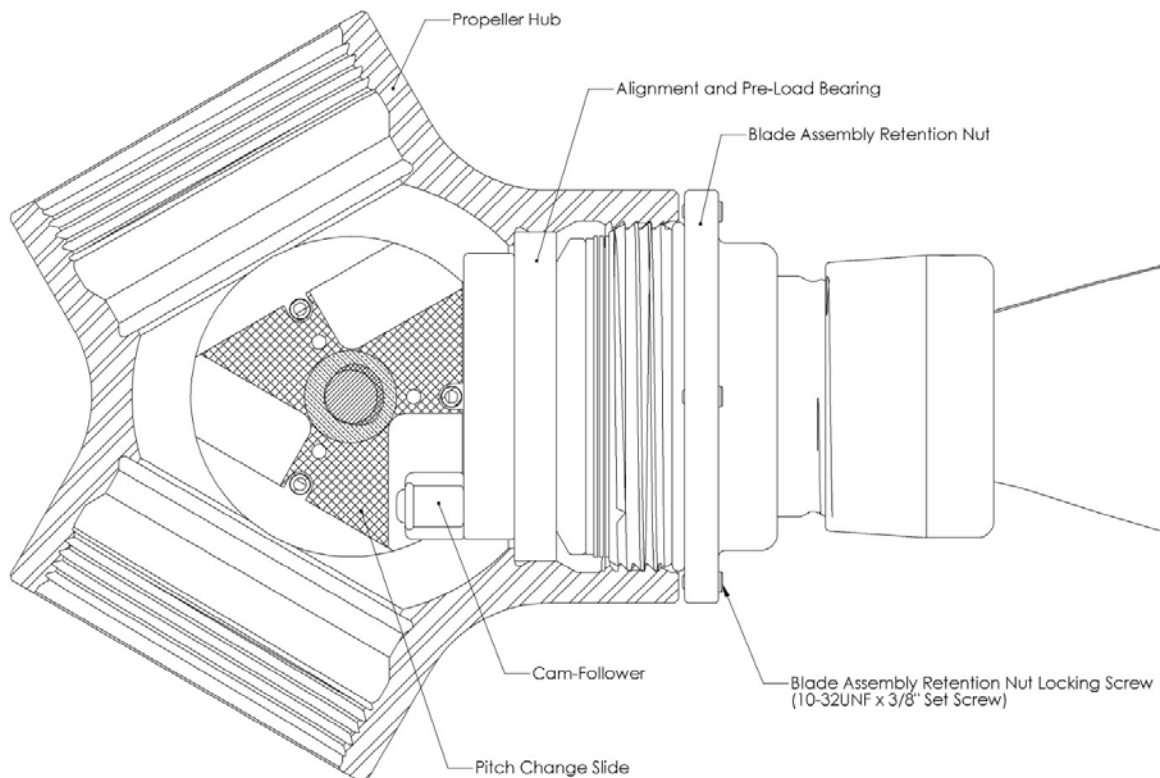

**Figure 8. Blade Assembly (AP332 shown)**

- d. Lubricate the Blade Assembly i.a.w. Airmaster Service Letter AP-D-009
- e. Insert the blade assembly in the hub blade assembly mounting bore with the matching number, while carefully lining up the cam-follower so that it slides into the slot on the pitch control slide. Care should be taken with the alignment of the blade assembly to ensure that the alignment and pre-load bearing is able to slide completely into the bore.

Note: By holding the blade assembly retention nut with one hand while moving the tip of the blade slightly from side to side, the correct alignment is easily found.

- f. Tighten the blade assembly retention nut by hand (3-series) or using C-spanner (4-series) until the blade assembly is fully inserted in the hub.



**Figure 9. Blade Assembly Mounted into Propeller Hub (AP332 shown)**

- g. Firmly tighten the blade assembly retention nut by using the special blade assembly spanner that is provided, to ensure that the blade assembly is fully located in the hub.

Note: Use the spanner on the 3-series as follows. Ensure that the four 10-32UNF set-screws on each blade assembly retention nut are loosened so that they protrude approximately 4mm(3/16in) from the blade assembly retention nut. The spanner may be fitted over these set-screws, and acts upon them to tighten blade assembly retention nut.

- h. Loosen the blade assembly retention nut a quarter of a turn.
- i. Re-tighten the blade assembly retention nut with the blade assembly spanner to achieve pre-load torque. This action provides the pre-load on the blade thrust bearing.

	3-series	4-series
Pre-load Torque	10.5 Nm (8ft-lb)	15 Nm (12 ft-lb)

Note: A torque wrench with a 3/8in drive may be used on the blade assembly spanner. The torque wrench should be rotated so that it makes an angle of 90° with the arm of the blade assembly spanner in order that the set torque may be used directly. If the torque wrench is used in line with the arm, a higher torque than that of the wrench will be applied. This torque may be calculated if the length of the wrench is known using the ratio of levers method, as used with a crow's foot extension or a torque adapter.

- j. For the 3-series, remove, and re-install the four 10-32UNF x 3/8in set-screws with low strength thread-locking compound such as Loctite 222, to lock the blade assembly retention nut.

For the 4-series, install the retention plate into one of the holes in the retention nut and check for alignment between the holes on the front of the hub and any two of the holes on the retention plate. If required, further tightening of the retention nut in the hub may be used to align two holes. Install screws two places and lock wire using 0.025 inch lock wire to lock the blade assembly retention nut

- k. Repeat for the remaining blades.
- l. Check the assembly of each blade by the following methods:
  - i. Apply a moderate torque by twisting with one hand only and monitor the movement produced. No movement should be evident between the blade and the ferrule into which it is mounted. A slight perceptible movement between the ferrule and the hub is acceptable, which is due to backlash in the pitch change mechanism.
  - ii. Apply a moderate force to the end of the blade with one hand only and monitor the movement produced. Ignore the deflection due to the bending of the blade itself. No movement should be evident between the blade and the ferrule into which it is mounted. A slight perceptible movement between the ferrule and the hub is acceptable.

Note: The reduction gearbox on the Rotax engines has a discernible backlash. Do not confuse this backlash with movement of the blade within the hub.

Note: After the propeller is run for the first time, operators may observe seepage of yellow jointing compound from the blade root area of the blade assembly. This compound is used during manufacture, and such seepage is normal for the first few runs. The blades should be wiped clean with a rag. The rag may be moistened with kerosene or methylated spirits if necessary.

## **Part 5.6. Spinner Installation**

The spinner assembly comes pre-fitted to the hub assembly from the factory. Re-fitting of the cone should be performed as follows:

Note: Polished spinner cones are easily marked. A soft cloth or glove should be used when handling these finish types.



- a. Fit the spinner cone to the propeller hub assembly, ensuring correct orientation by aligning the stamped '1' marks on the spinner and the spinner back-plate (the marks should be adjacent to blade 1).
- b. Check the fit of the spinner cone is snug and the retaining screw holes align correctly with the backplate nut-plate holes.
- c. If the screw mounting holes do not align, adjust the front support accordingly
  - i. Remove the three 10-32UNF screws (P0107) that secure the spinner support to the motor cap.
  - ii. Rotate the spinner support until the screw spinner alignment is correct
  - iii. Replace the three screws locking the spinner support to the motor cap and make hand tight.

**Caution:** Do not over-tighten the securing screws as this could stress the front support.

- iv. Lock-wire the three screws in place
- d. Recheck (b) above.
- e. Install the truss head screws and white vulcanised fibre washers to retain the spinner.

## Part 5.7. Installation of AC200 SmartPitch Controller

### Section 5.7.1. Introduction

The AC200 SmartPitch Controller is a constant speed propeller controller designed to work exclusively with Airmaster variable pitch propellers. Installation of the AC200 SmartPitch Controller will vary with different aircraft and engine combinations. The following instructions, therefore, are a guide to installation, and the owner should design an installation to suit the aircraft using accepted aviation practices.

The controller consists of the following three units:

- **AC200 Control Unit.** The AC200 control unit is the core of the system, and is mounted in the aircraft instrument panel. This unit is connected to the aircraft power supply.
- **Manual Control Switch.** The manual control switch allows manual over-ride operation of the controller. It may be mounted in the aircraft instrument panel, usually close to the throttle control.
- **Sensor/Brush Assembly.** The sensor/brush assembly is used by the controller to sense the rotational speed of the propeller, and to pass electric power to the propeller's pitch change mechanism. It is mounted to the front of the engine or reduction gearbox in such a way that it comes in contact with the propeller via the brushes and slip-rings.

The three units are supplied with custom manufactured cables, and are connected as indicated in the following diagram:

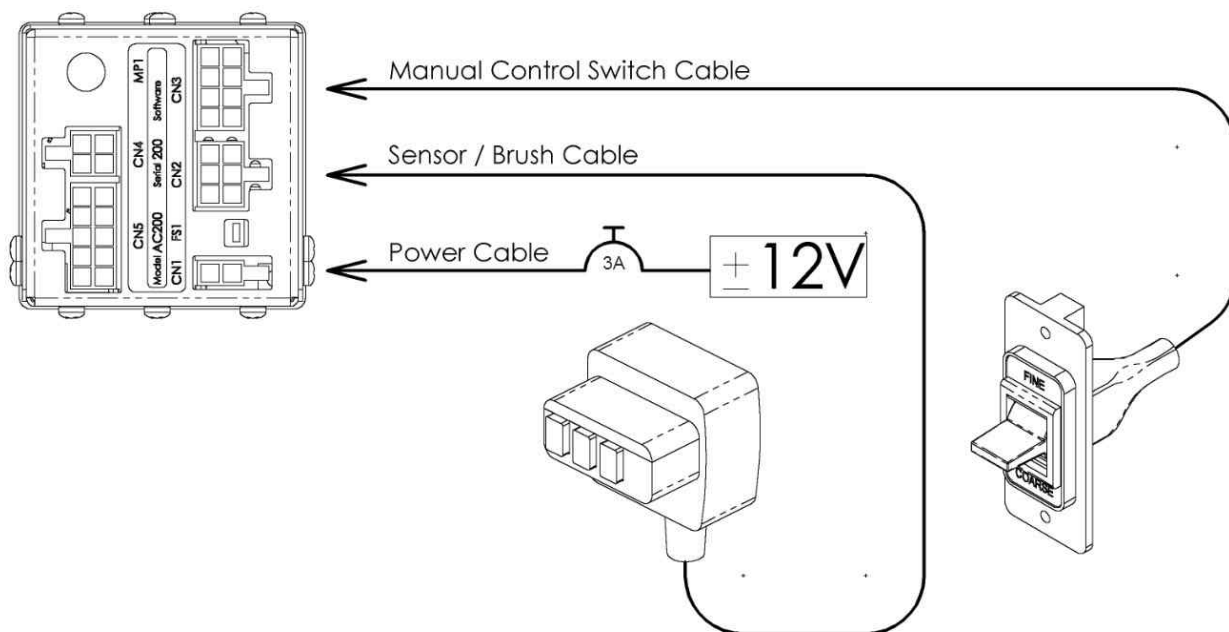

**Figure 10. AC200 SmartPitch Controller Cable Installation and Rear View of Control Unit**

The control unit is connected to other units in the system via connectors on the rear of the unit and the custom manufactured cables supplied. The connectors and other controls that are found on the rear face of the unit are identified in the following table:

Identification Code	Description	Function
CN1	2 way Connector	Power Supply
CN2	6 way Connector	Sensor/Brush Cable
CN3	8 way Connector	Manual Control Switch Cable
CN4	4 way Connector	Serial Programming Cable
CN5	10 way Connector	Auxiliary Input/Output (future development)
FS1	Thermal circuit breaker	Reset for controller’s internal current protection
MP1	Air pressure sensor	(future development)

**Note:** For a detailed table of the individual wires within the cables and corresponding connector pins, see ANNEX B. AC200 SmartPitch Controller Cables, Wires and Connector Pins.

**Note:** For further detailed information about the wiring within the propeller hub and its connection to the controller, see ANNEX C. Propeller Hub and Sensor/Brush Assembly Wiring.

**Caution:** When connecting other units to the AC200 control unit, ensure that cable connectors are pushed all the way home into the control unit, and that the latch on their side is fully engaged. Access to the connectors may be difficult once the unit is mounted in the instrument panel.

### Section 5.7.2. AC200 Control Unit

The AC200 control unit should be mounted in the instrument panel in a position where it will be easily accessible and visible to the pilot. It is recommended that the control unit be positioned near the engine controls and instrumentation. It should be positioned away from magnetically sensitive instruments like the aircraft compass.

The AC200 control unit is designed to be mounted in a standard 2-1/4in instrument cutout (see ANNEX D. Instrument Panel Cutout for AC200 SmartPitch Controller). It is attached with standard 6-32UNC brass instrument screws such as MS35214-29. Its dimensions for installation are as indicated in the following diagram:

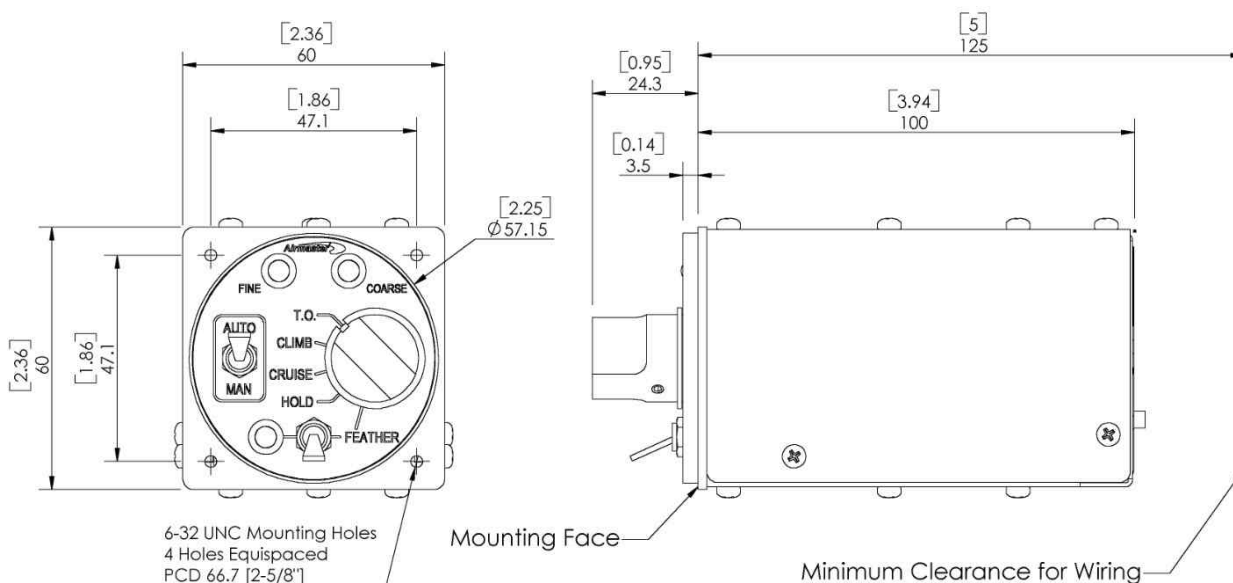

NB: Primary dimensions in millimeters [Secondary dimensions in inches]

**Figure 11. AC200 Control Unit Installation Dimensions**

**Power Supply.** The power cable provided with the AC200 control unit must be connected to the aircraft electrical system via an independent circuit breaker with the polarity indicated on the cable. An electrical supply of +12V nominal should be used to power the control system (acceptable variance: 10V to 14V). Connect the wire coloured white with red stripe to the +12V DC supply, and connect the wire coloured white with black stripe to ground. A 3A circuit breaker should be used. It is recommended that the main bus be used to provide power to the propeller system.

The circuit breaker protection is supplemented by two forms of over-current protection designed into the control system:

- **Internal Current Monitoring.** Should the current drawn by the pitch change motor during automatic operation exceed a value set in the controller software (typically 2.5A), the controller will temporarily disable and cease to drive the propeller pitch. This function may be reset in flight by briefly selecting manual over-ride and then back to automatic. (see section 10.1.5 Manual Control Switch)
- **Internal Fuse (FS1).** All automatic functions of the controller draw power through an internal fuse (FS1). This fuse will trip when the total current drawn by the system during

automatic operation exceeds 3.15A, and may be reset by pushing the button on the rear of the controller. Manual over-ride operation of the propeller bypasses this internal fuse, ensuring manual over-ride operation of the propeller is still possible in the event of the fuse tripping.

### Section 5.7.3. Manual Control Switch

The manual control switch should be mounted in the instrument panel near to the AC200 control unit. The manual control switch is used in conjunction with the aircraft throttle so it is recommended that it be positioned adjacent to it. An arrangement where the hand may operate the throttle while the switch is operated by the index finger is suggested as ideal.

The manual control switch must have its own cutout in the instrument panel. It is designed with mounting holes at the same spacing as found in a standard 2-1/4in instrument cutout (see ANNEX D. Instrument Panel Cutout for AC200 SmartPitch Controller). It is attached with standard 6-32UNC brass instrument screws such as MS35214-29. Its dimensions for installation are as indicated in the following diagram:

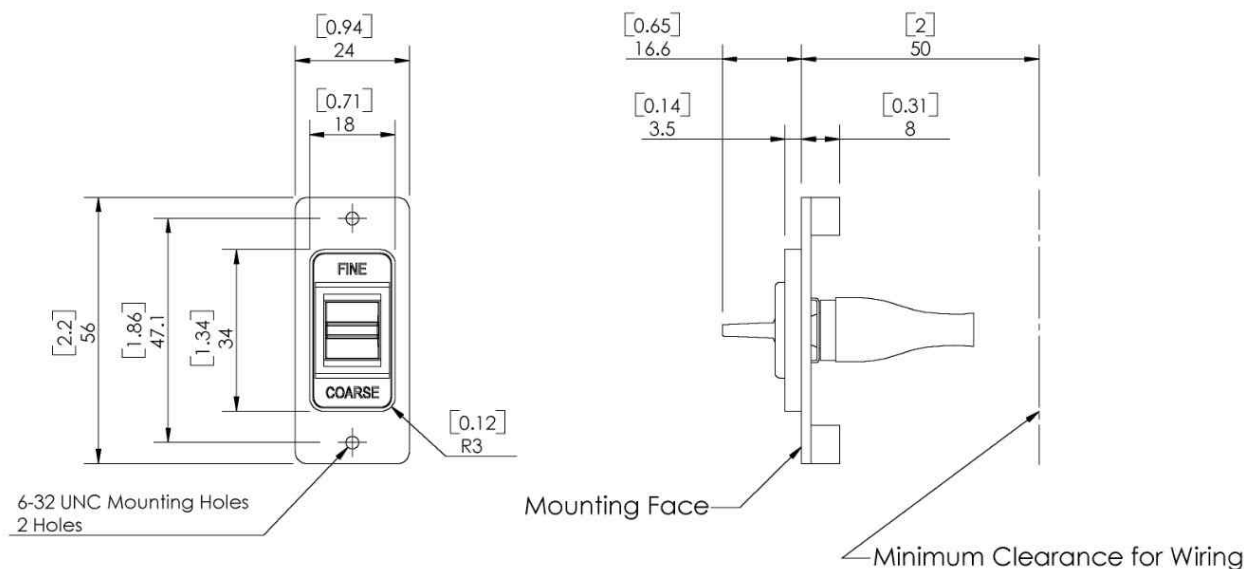

NB: Primary dimensions in millimeters [Secondary dimensions in inches]

**Figure 12. Manual Control Switch Installation Dimensions**

### Section 5.7.4. Sensor/Brush Assembly

The sensor/brush assembly is mounted to the front of the engine by a special bracket. Two different brackets are available for the Rotax and Jabiru engines. The cable loom from the sensor/brush assembly is then routed through the engine bay and fuselage to the AC200 control unit in the instrument panel.

**Caution:** The carbon brushes are very delicate. Take care not to break them.

**Note:** See Section 11.3.2, Replacement of Slip-Ring Brushes, for instructions on replacing the slip-ring brushes, should they become damaged or worn.

As the sensor/brush assembly is positioned, a piece of card should be used to protect the brushes as they slide across the slip-ring assembly. The sensor/brush assembly should be mounted so that the carbon brushes run centrally in the slip-rings, and the distance from the front of the brush holder (plastic component protruding from sensor/brush assembly) to the slip-rings does not exceed 2mm(0.08in). If either the brushes do not run centrally or the mounting distance is incorrect, small modifications to the mounting bracket may be required.

**Rotax Engine.** Use two 8mm bolts and washers supplied to mount the bracket to the boss on left side of the reduction gearbox. Torque the bolts to 10Nm(7ftlb). Lock-wire the bolts with 0.024in lock-wire. The sensor/brush assembly is mounted as indicated in the following diagram:

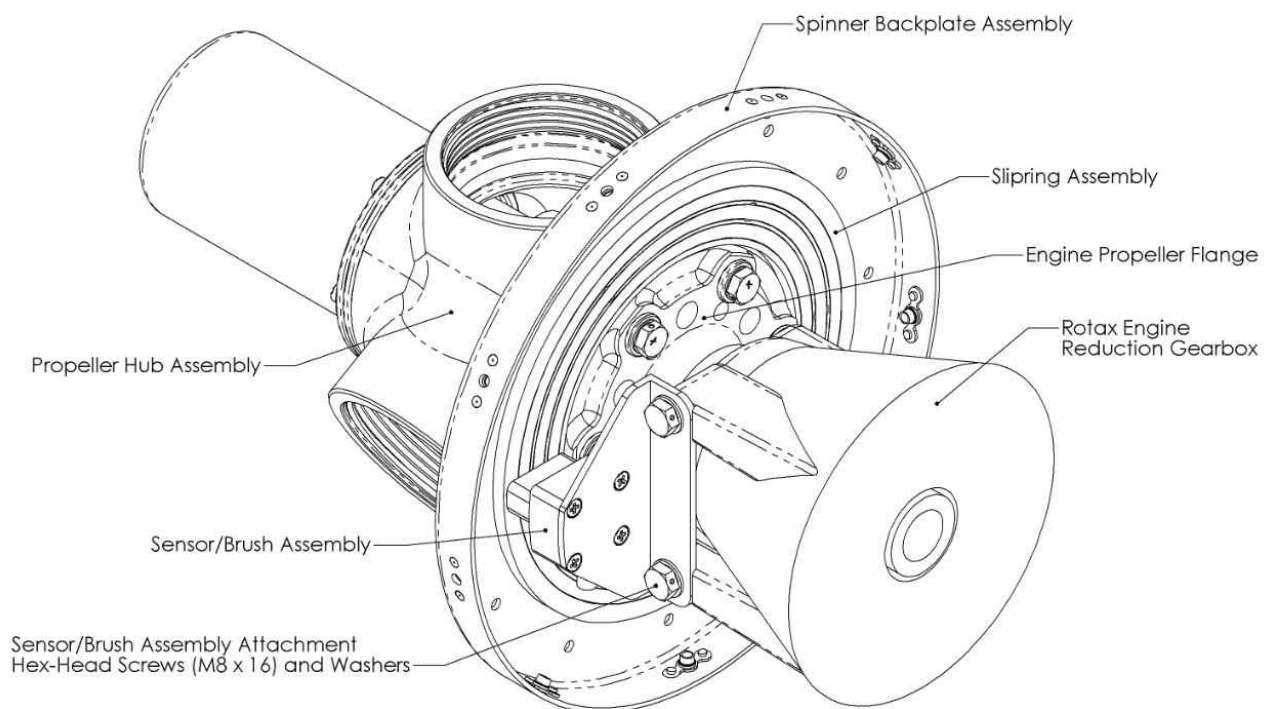
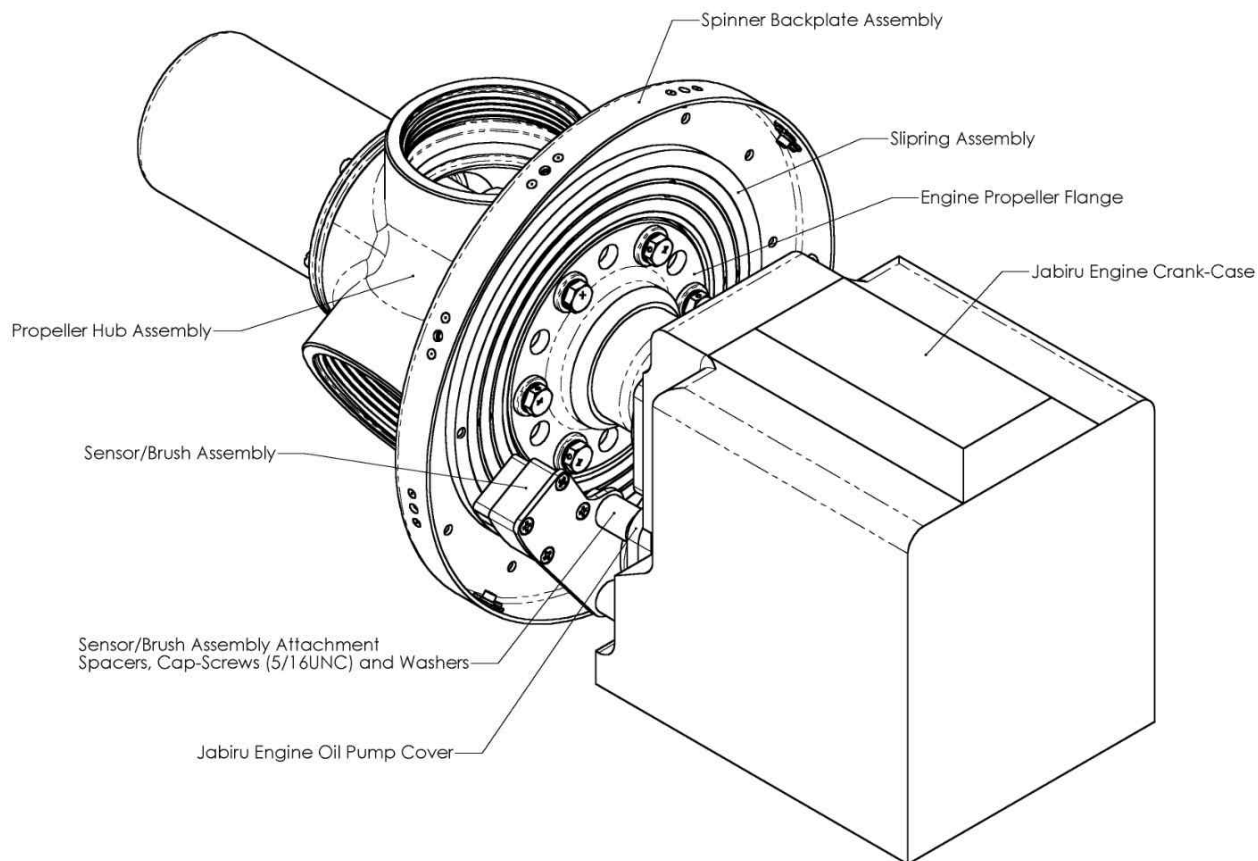

**Figure 13. Illustration of the Sensor/Brush Assembly Mounted on a Rotax Engine (AP332 shown)**

**Jabiru Engine.** Remove the two left-most 5/16UNC cap-screws that retain the oil pump cover on the front of the engine crankcase. Mount the bracket to this point by using the spacers, cap-screws and washers supplied. The components should be installed in the following order: spacers (shaped to fit beside oil pump cover), bracket, washers and cap-screws. The following cap-screws are required:

- Standard Propeller Flange. 5/16UNC x 2-1/4in. (AP-P-0296).
- 2-Inch Extension Propeller Flange. 5/16UNC x 4in. (AP-P-0297).

Install these cap-screws with medium strength thread-locking compound such as Loctite 243. Torque the cap-screws to 20Nm(15ftlb), and lock-wire with 0.024in lock-wire. The sensor/brush assembly is mounted as indicated in the following diagram:



**Figure 14. Illustration of the Sensor/Brush Assembly Mounted on a Jabiru Engine (example shows standard flange without prop extension/AP332)**

**Routing Cable Loom.** The cable loom for the sensor/brush assembly should be installed to suit the engine installation. The cable loom should be routed through the engine bay avoiding areas of excessive heat and secured with wire ties every 100-200mm(4-8in).

**Firewall Penetration.** Where the cable loom passes through the firewall, a 20mm(3/4in) hole will be required to pass the cable connector through. After installation, the hole should be resealed and the cable protected as necessary. A stainless steel firewall shield is supplied to provide the necessary protection if desired. The grommet found along the length of the cable loom should be slid to the correct position on the loom and the two-part firewall shield assembled around the grommet. The firewall shield may be attached to the firewall with #10 sheet metal screws, or may be drilled out to take a 10-32UNF fastener (drill with 5mm or #9 number drill). The firewall shield may be further sealed with HT silicon if required.

Note: FAA Advisory Circular AC43.13-1B (Acceptable Methods, Techniques and Practices – Aircraft Inspection and Repair), Chapter 11 (Aircraft Electrical Systems) provides good advice on the installation of electrical equipment.

## Part 5.8. Manifold Air Pressure Gauge

The manufacturer does not require that a Manifold Air Pressure (MAP) gauge be fitted as part of an installation of an Airmaster propeller onto a Rotax or Jabiru engine. As these engines have no published MAP limits, operators do not need to be concerned with exceeding the limits, as they do with some other aircraft engines.

However operators of Airmaster propellers may wish to have a MAP gauge fitted to their aircraft, and should also consider the advantages of a MAP gauge when making their decision.

If fitted, a MAP gauge offers the following advantages:

- A MAP gauge provides an indication of the engine power, when used in combination with the tachometer. Some engines are supplied with charts of power output, which allow the power output to be determined from a given engine speed and manifold air pressure.
- A MAP gauge may provide an indication of a loss of power that is not accompanied by a decrease in engine speed. This is because the normal operation of a constant speed propeller will cause the engine speed to be maintained at the governed speed during a partial loss of power. Power loss due to carburettor icing or throttle failure is an example of the type of power loss that will cause this behaviour.

Some aircraft approval organisations, such as the Popular Flying Association in United Kingdom, require that a MAP gauge be fitted whenever a constant speed propeller is fitted. Operators should be aware of such requirements when installing an Airmaster propeller.

## Part 5.9. Weight and Balance

The operator of the aircraft must account for installation of the Airmaster propeller on the aircraft's weight and balance. The operator must ensure that the weight and balance remains within the limits specified by the aircraft manufacturer after installation of the new propeller.

**WARNING:** This task is the operator's responsibility. The manufacturer is unable to assess the weight and balance of the operator's aircraft, and the change the new propeller will have on this.

Information is provided in Chapter 3 for calculation of the weight and balance change associated with installation of the Airmaster 3 & 4 series propellers. Those values are based on 3 & 4 series propellers with a 262 mm (10.3 in) spinner and a diameter of 64 in. These figures will vary by a small amount with other configurations.

Centre of Gravity position varies with propeller model:

For 3 series propellers                      66 mm (2.6in) forward of the engine propeller flange.

For 4 series propellers                      70 mm (2.8 in) forward of the engine propeller flange.

(This position is the plane of the propeller blades. See ANNEX A. Principal Dimensions of Propeller Installations. Variation of the centre of gravity of the propeller from this position will be negligible.)

## CHAPTER 6. BEFORE FLIGHT FUNCTIONAL CHECK

Note: This procedure incorporates control of the propeller with the AC200 SmartPitch Controller. It is recommended that the operator become familiar with operation of the controller by reading 10, Operation of AC200 SmartPitch Controller, before carrying out this procedure.

Note: The following notation will be used in these instructions to state the required position of the controls on the AC200 SmartPitch Controller:

<Automatic/Manual Selector> / <Propeller Control Selector>

eg AUTO/CLIMB means that the automatic/manual selector should be set to AUTO and the propeller control selector should be set to CLIMB.

Note: 'Pitch Limit' refers to that pitch setting determined by the applicable adjustable pitch stop. See CHAPTER 9, Set-Up of Propeller Pitch Stops.

### Part 6.1. Engine Off Functional Check

#### Section 6.1.1. Introduction

After installation of the propeller system, an initial check of its function with the engine off is required to ensure that it operates correctly. This must take place before the engine/propeller combination is first run. This check ensures the correct static operation of the propeller pitch change mechanism, the adjustable pitch stops, and basic functions of the AC200 SmartPitch Controller.

Note: The following procedure is a functional check only. The actual pitch limits may not be correct for flight, and will be set later. See CHAPTER 9, Set-Up of Propeller Pitch Stops.

#### Section 6.1.2. Manual Over-Ride Operation

The following functional check procedure should be followed to check operation of the propeller using manual over-ride:

- a. Turn aircraft power on.
- b. Select MAN on the automatic/manual selector.
- c. Actuate and hold FINE on the manual control switch. The propeller blades should reduce pitch smoothly towards the fine pitch limit. While the pitch is reducing the fine indicator should illuminate orange.
- d. Upon the propeller reaching the fine pitch limit the fine indicator should change to illuminate flashing green and the pitch change motor should stop, halting movement of the blades.
- e. Release the manual control switch. The fine indicator should remain illuminated steady green.



- f. Actuate and hold COARSE on the manual control switch. The propeller blades should increase pitch smoothly towards the coarse pitch limit. While the pitch is increasing the coarse indicator should illuminate orange.
- g. Upon the propeller reaching the coarse pitch limit the coarse indicator should change to illuminate flashing green and the pitch change motor should stop, halting movement of the blades
- h. Release the manual control switch. The coarse indicator should remain illuminated steady green.
- i. Repeat the above actions to move the propeller from the coarse pitch limit to the fine pitch limit and return. The time to traverse each full pitch range should be 5-10 seconds (depending where the pitch limits are currently set).

#### Section 6.1.3. Manual Feather Operation (Option)

- a. Actuate and hold the feather engage switch, and actuate and hold COARSE on the manual control switch. The propeller blades should increase pitch smoothly towards the feather pitch limit. While the pitch is increasing the feather indicator should illuminate orange.
- b. Upon the propeller reaching the feather pitch limit the feather indicator should change to illuminate flashing green and the pitch control motor should stop, halting movement of the blades.
- c. Release both switches. The feather indicator should remain illuminated steady green.
- d. Actuate and hold FINE on the manual control switch. The propeller blades should reduce pitch smoothly towards the fine pitch limit. While the pitch is reducing the fine indicator should illuminate orange.
- e. Upon the propeller reaching the fine pitch limit the fine indicator should change to illuminate green and the pitch change motor should stop, halting movement of the blades.

**Optional Blade Set-up Check.** At the completion of this functional check, the pitch setting of each blade may be checked to ensure that the blade set-up is correct. This check requires the use of a propeller protractor. If one is available, check that the blade angles are within  $0.5^\circ$  at the point of 75% blade radius.

Note: See CHAPTER 9, Set-Up of Propeller Pitch Stops for more details on measurement of blade angle.

#### Section 6.1.4. Automatic Feather Operation (Option)

The following functional check procedure should be followed to check automatic operation of the propeller:

- a. Turn aircraft power on.
- b. Select AUTO/CRUISE. The fine indicator should flash orange.

- c. Select AUTO/FEATHER.
- d. Actuate the feather engage switch for approximately one second and release. The propeller blades should increase pitch smoothly towards the feather pitch limit.
- e. Observe the coarse indicator flashing red (5Hz 75%) to indicate the coarse pitch stop has been bypassed. Observe the feather indicator illuminated orange.
- f. Once the propeller is fully feathered the feather indicator should change to illuminate green and the pitch control motor should stop, halting movement of the blades.
- g. Select any other control mode on the propeller control selector (eg AUTO/CRUISE). The propeller blades should reduce pitch smoothly towards the flight range. While the pitch is reducing the fine indicator should illuminate orange.
- h. Once the propeller is in the flight range (somewhere between the fine and coarse pitch limits) the fine indicator should change to flash orange, and the pitch control motor should stop, halting movement of the blades.

Note: A brief pause in the blade movement may be observed during the un-feather cycle, before the movement continues. This is normal.

#### Section 6.1.5. Automatic Beta Operation (Option)

The following functional check procedure should be followed to check automatic operation of the propeller using Beta:

- a. Turn aircraft power on.
- b. Select AUTO/CRUISE. The fine indicator should flash orange.
- c. Select AUTO/BETA.
- d. Initiate Beta control (momentarily use the Beta engage switch). Observe the FINE indicator led flashing red ~1Hz 10% duty cycle. This signifies the fine pitch stop will be in over-ride.
- e. Select MAN. Observe the FINE indicator led flashing red ~5Hz 75% duty cycle. This signifies the fine pitch stop is in over-ride.
- f. Use the FINE/COARSE switch to move the propeller past the fine stop into the Beta pitch region. Ensure that the propeller pitch moves smoothly. Ensure that the BETA indicator illuminates orange while the propeller pitch decreases, and green (flashing) once it hits the Beta stop.
- g. Select AUTO/ CLIMB, Observe the propeller moving in a coarse direction past the fine pitch stop. Auto control will resume after ~15 seconds.

## Part 6.2. Engine Running Functional Check

### Section 6.2.1. Introduction

After functionally checking the propeller system with the engine off, a check of its function while the engine is running is required. This must take place before the aircraft is flown. This check ensures the correct operation while rotating of the propeller pitch change mechanism, the adjustable pitch stops, and constant speed governing functions of the AC200 SmartPitch Controller.

**WARNING:** The aircraft should be securely anchored with tie downs or chocks to allow testing at maximum thrust. Due to the high thrust this propeller is able to produce, the aircraft brakes and wheels must not be relied on.

**Caution:** The following procedure may be carried out before the propeller has been dynamically balanced. If an unacceptable vibration is observed during this procedure, the procedure should be halted, and a dynamic balance check carried out before proceeding. See CHAPTER 8, Dynamic Balance.

**Caution:** The engine temperature and pressure should be monitored during high power engine running on the ground, due to the possibility of inadequate engine cooling. If the engine temperature and pressure limits are exceeded, the test should be halted, and the engine allowed to cool before continuing.

The following procedure should be followed to check the automatic operation of the controller after initial installation.

### Section 6.2.2. Manual Over-Ride Operation

The following functional check procedure should be followed to check operation of the propeller using manual over-ride:

- a. Turn aircraft power on.
- b. Select MAN on the automatic/manual selector.
- c. Actuate and hold FINE on the manual control switch until the propeller reaches the fine pitch limit (indicated by the fine indicator illuminating green).
- d. Start the engine using the normal procedure, and allow it to warm up.
- e. Smoothly increase the throttle to achieve approximately cruise engine speed.
- f. Actuate and hold COARSE on the manual control switch for a short time. The engine speed should be observed to decrease.
- g. Actuate and hold FINE on the manual control switch until the propeller reaches the fine pitch limit (indicated by the fine indicator illuminating green). The engine speed should be observed to increase.
- h. Reduce the throttle to achieve a fast idle.

### Section 6.2.3. Automatic Operation

The following functional check procedure should be followed to check automatic operation of the propeller:

**Caution:** Care should be taken not to exceed the maximum permissible speed of the engine, or to exceed the time limit above the maximum continuous speed. Should either of these limits tend to be exceeded the throttle should be reduced to maintain the engine speed within limits.

- a. With the engine running at a fast idle, select AUTO/CRUISE. The fine indicator should **not** flash orange.
- b. Smoothly increase throttle setting until cruise pre-set speed is reached. The propeller should be observed to govern, and the speed should remain approximately constant if the throttle is increased further. The fine and coarse indicators may illuminate briefly as the controller makes pitch corrections.

Note: See leading particulars section of the propeller logbook for the pre-set speeds.

- c. Select AUTO/CLIMB.
- d. Smoothly increase throttle setting until climb pre-set speed is reached. The propeller should be observed to govern, and the speed should remain approximately constant if the throttle is increased further. The fine and coarse indicators may illuminate briefly as the controller makes pitch corrections.

Note: The higher speed settings such as climb and take-off may not be able to be achieved at this point, due to the current setting of the fine pitch limit. If this is the case, return to this functional check after setting the adjustable pitch stops. See CHAPTER 8, Set-Up of Propeller Pitch Stops.

- e. Select AUTO/T.O.
- f. Smoothly increase throttle setting until take-off pre-set speed is reached (if sufficient throttle is available). The propeller should be observed to govern, and the speed should remain approximately constant if the throttle is increased further. The fine and coarse indicators may illuminate briefly as the controller makes pitch corrections.
- g. Select AUTO/HOLD. The propeller should be observed to govern at the current hold speed setting (this setting will be the same as the pre-set cruise speed if the power has been removed from the controller since hold speed governing mode was last used).
- h. Actuate the manual control switch briefly to COARSE before releasing. Confirm that the hold speed setting has decreased, and that the propeller continues to govern at the new speed.
- i. Actuate the manual control switch briefly to FINE before releasing. Confirm that the hold speed setting has increased, and that the propeller continues to govern at the new speed.
- j. Reduce the throttle to idle, allow the engine to cool and shut down.

**Note:** After the propeller is run for the first time, operators may observe seepage of yellow jointing compound from the blade root area of the blade assembly. This compound is used during manufacture, and such seepage is normal for the first few runs. The blades should be wiped clean with a rag. The rag may be moistened with kerosene or methylated spirits if necessary.

At the completion of these functional checks, the operator should proceed to the set-up of the propeller pitch stops (see CHAPTER 9, Set-Up of Propeller Pitch Stops). Do this while the aircraft is still tied down, and before flight.

If not already completed, the propeller should also be dynamically balanced before flight (see CHAPTER 8, Dynamic Balance).

#### Section 6.2.4. Automatic Operation (Beta Option)

The following functional check procedure should be followed to check automatic operation of the propeller:

**Caution:** Care should be taken not to exceed the maximum permissible speed of the engine, or to exceed the time limit above the maximum continuous speed. Should either of these limits tend to be exceeded the throttle should be reduced to maintain the engine speed within limits.

- a. With the engine running at a fast idle, select AUTO/CRUISE. The fine indicator should **not** flash orange.
- b. Increase engine speed to ~4000rpm (Rotax)
- c. Select AUTO/BETA.
- d. Initiate Beta control (momentarily use the Beta engage switch). Observe the FINE indicator does **not** continue to flash after the engage switch is released. This shows that reverse cannot be initiated while at flight rpm.
- e. Reduce engine speed to ~1500rpm
- f. Initiate Beta control (momentarily use the Beta engage switch). Observe the FINE indicator led flashing red ~1Hz 10% duty cycle. This signifies the fine pitch stop will be in over-ride.
- g. Select MAN. Observe the FINE indicator led flashing red ~5Hz 75% duty cycle. This signifies the fine pitch stop is in over-ride.
- h. Use the FINE/COARSE switch to move the propeller past the fine stop into the Beta pitch region. Ensure that the propeller pitch moves smoothly. Ensure that the BETA indicator illuminates orange while the propeller pitch decreases, and green (flashing) once it hits the Beta stop.
- i. Increase engine speed to ~4000rpm
- j. Use the FINE/COARSE switch to move the propeller past the fine stop into the Beta pitch region. Observe the propeller will not move in the Beta direction while the engine

speed is above 3500rpm (Rotax). Engine speed should be kept below 3000rpm (Rotax) while propeller is commanded to move in Beta direction.

- k. Reduce engine speed to ~1500rpm
- l. Select AUTO/ CLIMB, Observe the propeller moving in a coarse direction past the fine pitch stop. Auto control will resume after ~15 seconds.

## CHAPTER 7. DYNAMIC BALANCE

Before flight, the dynamic balance of the propeller should be checked and corrected if out of limits. The dynamic balancing operation should take place with the propeller fully assembled, including the spinner. The dynamic balancing operation should take place with the propeller at the fine pitch limit.

**Caution:** As the propeller fine pitch limit may not yet have been set-up, the engine and propeller may over-speed if full throttle is used. The throttle should be controlled to prevent this happening, and to set the desired speed for dynamic balancing.

Any suitable dynamic balance equipment may be used in accordance with the equipment's instructions and standard practices. A vibration limit of 0.2IPS is recommended.

If the propeller is found to be out of balance, weight will have to be added to the propeller to correct this. Trial weights may be retained by the spinner screws during intermediate runs with the dynamic balance equipment; however the different diameter of the final installation will have to be accounted for on the dynamic balance equipment to calculate the correct final weight.

**Caution:** Ensure that a spinner screw sufficiently long to achieve full engagement in its nut-plate is used to hold the required weight.

For the permanent installation, weights should be added to spinner back-plate after removal of the spinner. The spinner back-plate of the propeller has holes already manufactured to take balance weights. There are twelve of these holes and they are spaced equally about the spinner back-plate. This arrangement facilitates positioning of the balance weights using the clock angle system employed by many types of dynamic balance equipment. The weight should be added at the clock angle specified by the dynamic balance equipment.

**212mm(8.3in) Spinner Balance Weight Arrangement.** The 212mm(8.3in) spinner back-plate has twelve countersunk balance holes in the flange of the back-plate at a diameter of 204mm(8.031in). Make up a balance weight assembly with a MS24694S# countersunk head screw (8-32UNC thread), a MS21044N08 locknut, and a combination of standard and flat (penny) washers. The flat washers will require trimming to fit in the space available on the flange. Use a standard washer between the curved flange of the spinner back-plate and the first flat washer to accommodate the curvature. Do not use more than four washers at a single location. The following diagram shows a sample installation:

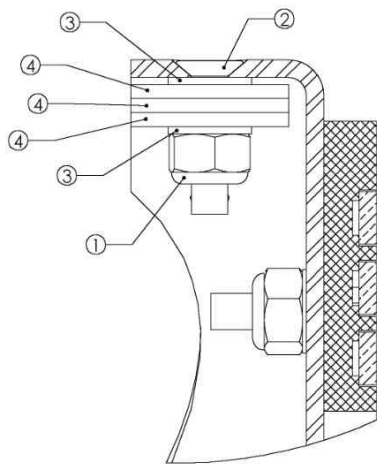

Item No.	Part Number	Description
1	MS21044N08	Locknut, 8-32UNC
2	MS24694S8	C-sunk Head Screw, Struct, 8-32UNC x 11/16"
3	NAS1149FN832P	Washer, #8 x 0.032"
4	AN970-3 (modified by APL)	Washer, Flat, #10 x 0.063" (modified)

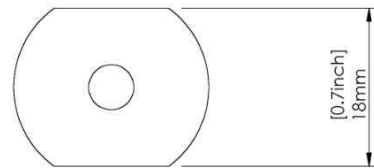

Typical Modified AN970-3 Washer

**Figure 15. Sample Balance Weight Installation on 212mm(8.3in) Spinner Back-Plate**

**228mm(9in) Spinner Balance Weight Arrangement.** The 228mm(9in) spinner back-plate has twelve countersunk holes in the flat area of the back-plate at a diameter of 202mm(7.953in). Make up a balance weight assembly with a MS24694S# countersunk head screw (8-32UNC thread), a MS21044N08 locknut, and a combination of standard and flat (penny) washers. The flat washers will require trimming to fit within the spinner. Do not use more than eight standard washers or four flat washers at a single location. The following diagram shows a sample installation:

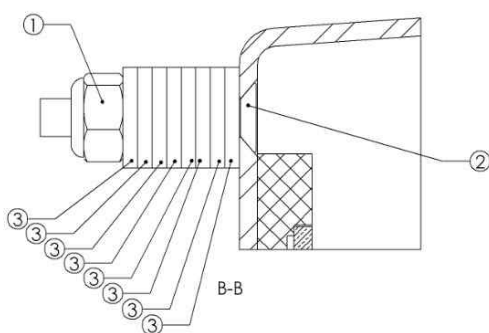

Item No.	Part Number	Description
1	MS21044N08	Locknut, 8-32UNC
2	MS24694S12	C-sunk Head Screw, Struct, 8-32UNC x 15/16"
3	NAS1149F0363P	Washer, #10 x 0.063"

**Figure 16. Sample Balance Weight Installation on 228mm(9in) Spinner Back-Plate**

**262mm(10.3in) and 285mm(11.2in) Spinner Balance Weight Arrangement.** The 262mm(10.3in) and 285mm(11.2in) spinner back-plates each have twelve balance holes in the flat area of the back-plate at a diameter of 220mm(8.661in). Make up a balance weight assembly with an AN3-#A bolt (10-32UNF thread), a MS21044N3 locknut, and a combination of standard and flat



(penny) washers. Do not use more than four washers at a single location. The following diagram shows a sample installation:

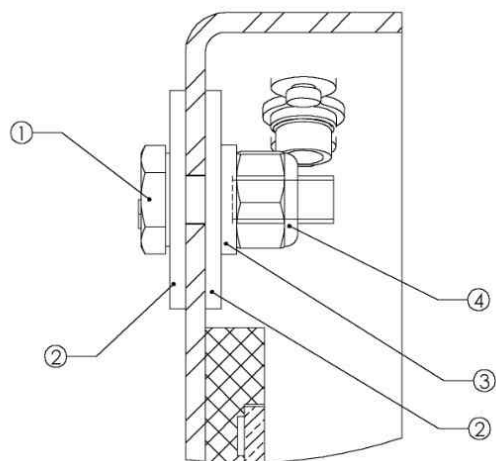

Item No.	Part Number	Description
1	AN3-5A	AN Bolt, 10-32UNF x 5/8"
2	AN970-3	Washer, Flat, #10 x 0.063"
3	NAS1149F0363P	Washer, #10 x 0.063"
4	MS21044N3	Locknut, 10-32UNC

**Figure 17. Sample Balance Weight Installation on 262mm(10.3in) and 285mm(11.2in) Spinner Back-Plates**

After installation of the balance weights, the spinner front support (if applicable) and spinner may be refitted in accordance with Part 5.6, Spinner Installation.

## CHAPTER 8. SET-UP OF PROPELLER PITCH STOPS

### Part 8.1. Propeller Pitch and Blade Angle

This chapter of the operator's manual deals with propeller pitch or blade angle, and control of this by way of pitch stops. In variable pitch propellers, propeller pitch or blade angle is measured from the reference plane (plane of rotation) of the propeller to the chord line at a reference blade station of the propeller blade, and is expressed in degrees. In accordance with industry standard practice, the manufacturer uses the following conventions:

- The reference blade station of the propeller is the station positioned at 75% of the propeller diameter. To find this station a measurement of 1/8 of the propeller diameter may be made in from the tip of the propeller blade. This station may be marked with a pen or pencil.
- The flat thrust face of the Warp Drive blade is assumed to be parallel to the chord line.

Note: Measurements of blade angle are not necessary to set-up or operate the propeller. The procedure detailed below for setting up the adjustable pitch stops is based on aircraft and engine performance, not blade angle.

If required the blade angle should be measured with a propeller protractor. A suitable low-cost propeller protractor is the type supplied by Warp Drive Inc, designed for use on Warp Drive blades. When used on an Airmaster propeller the starting point or reference plane may be determined by placing the edge of the protractor against the flat face of the propeller motor cap.

### Part 8.2. Fixed Pitch Stops

The propeller has two fixed (hard) pitch stops, which prevent the mechanism of the propeller moving the blade angles beyond these stops at any time. The fixed stops are set by the manufacturer at the positions indicated in the leading particulars section of the propeller logbook delivered with the propeller. These stops are not adjustable by the operator.

### Part 8.3. Adjustable Pitch Stops – Guidelines for Setting

#### Section 8.3.1. Introduction

The propeller has three adjustable (soft) pitch stops, which prevent the mechanism of the propeller moving the blade angles beyond these stops during normal operation of the propeller. To ensure correct operation of the propeller the operator should adjust these stops during set-up of the propeller.

Note: The pitch settings determined by the adjustable pitch stops are referred to elsewhere in this manual as 'pitch limits'.

The adjustment of each of the three adjustable pitch stops should be made to meet certain flight requirements. These requirements principally deal with the ability to maintain safe flight in all reasonable conditions, and also affect the performance delivered by the engine/propeller combination. The correct setting for each stop will be found using a combination of the following three methods performed in sequence.

- Ground static tests.
- Flight tests to verify safety of flight.
- In-Flight performance verification.

Note: These tests should all be performed with the controller inoperative (ie with the controller set to Manual). This is because it is the actual propeller pitch at the each applicable adjustable pitch stop that is important to each test, not the response of the controller.

The three adjustable pitch stops have the following ranges of adjustment:

Adjustable Pitch Stop	Range of Adjustment (blade angle)
Fine Pitch	10 – 27 degrees
Coarse Pitch	24 – 40 degrees
Feather Pitch (option)	65 – 89 degrees
Reverse Pitch (option)	-20 – 0 degrees

Note: For the method used to physically adjust the adjustable pitch stops, see Part 9.4, Adjustable Pitch Stops – Method of Adjustment, in this chapter.

### Section 8.3.2. Ground Static Tests

Ground static tests should be used for initial setting of the adjustable pitch stops. A static test is where the aircraft remains on the ground and is prevented from moving, ideally in zero wind conditions. The engine is then operated at full throttle, and the propeller pitch altered to achieve a certain engine/propeller speed.

**WARNING:** The aircraft should be securely anchored with tie downs or chocks to allow testing at maximum thrust. Due to the high thrust that variable pitch propellers can produce, the aircraft brakes and wheels should not be relied on.

**Caution:** During ground static tests, engine operating conditions such as temperature should be carefully monitored. Some engine installations are not designed for sustained high power running on the ground, and the engine should be allowed to cool between runs.

Note: If possible the operator may check that the engine is producing full power during ground static tests, to ensure that the propeller adjustable pitch stops are not set too fine. If a MAP gauge is fitted, the manifold air pressure may be checked against the full throttle value detailed in the engine operator's manual.

The following guidelines on static speeds should be followed:

- **Fine Adjustable Pitch Stop.** A propeller pitch corresponding to a static speed of approximately 100rpm less than the maximum speed is recommended for initial set-up. (ie 5700rpm for a Rotax or 3250rpm for a Jabiru.)

- **Coarse Adjustable Pitch Stop.** A propeller pitch corresponding to a static speed of approximately the minimum recommended operating speed for the engine is recommended for initial set-up. (ie approximately 4000rpm for a Rotax or 2200rpm for a Jabiru.)
- **Feather (Option) Adjustable Pitch Stop.** Typically adjustment of the feather pitch adjustable stop will not be required. The manufacturer sets the feather pitch adjustable stop to settings which have been established by testing.
- **Beta (Option) Adjustable Pitch Stop.** Typically adjustment of the beta pitch adjustable stop will not be required. The manufacturer sets the beta pitch adjustable stop to settings which have been established by testing.

### Section 8.3.3. Flight Tests to Verify Safety of Flight

After initial set-up of the adjustable pitch stops on the ground by way of static tests, verification of the stop settings may be made in flight. The propeller pitch at each stop should be checked so that it meets the safety of flight requirements outlined below.

**WARNING:** The flight testing required to verify these requirements involves unusual aircraft operations and requires a high level of pilot skill. Do not carry out these flight tests if you are not capable of carrying them out safely.

Note: These requirements are derived from requirements of organisations such as the FAA and JAA.

- **Fine Adjustable Pitch Stop.** The propeller pitch at the fine adjustable pitch stop must not allow the engine/propeller speed to exceed the maximum speed, during take-off and initial climb at an indicated airspeed of  $V_x$  (best angle of climb speed).
- **Coarse Adjustable Pitch Stop.** The propeller pitch at the coarse adjustable pitch stop must allow the following minimum performance criteria to be achieved:
  - **Balked Landing.** Climb at a steady gradient of 1/30 (3.3%) with full throttle applied, the landing gear and flaps extended for landing, and at an indicated airspeed of  $V_{ref}$  (reference landing approach speed). (This test may be performed with the flaps retracted if they may be quickly and safely retracted by the pilot during a balked landing go-around.) (This test may be carried out at sea-level, or more conservatively, may be carried out at the altitude of the highest airfield regularly visited.)
  - **Level Flight at 3000ft.** Level flight at an altitude of 3000ft with full throttle applied, the landing gear and flaps extended for landing, and at an indicated airspeed of  $V_{ref}$  (reference landing approach speed). (This test may be performed with the flaps retracted if they may be quickly and safely retracted by the pilot during a balked landing go-around.) (This test may be carried out at 3000ft above sea-level, or more conservatively, may be carried out at 3000ft above the altitude of the highest airfield regularly visited.)
- **Feather Adjustable Pitch Stop.** The propeller pitch at the feather adjustable pitch stop should cause the propeller to exhibit no tendency to rotate when gliding. This position

will represent the propeller configuration that produces the minimum drag. The initial feather pitch setting outlined above should produce this condition.

#### Section 8.3.4. In-Flight Performance Verification

During subsequent flight in the aircraft, the performance available should be monitored to ensure that it is not restricted by the pitch stop settings of the propeller. The following two examples are possible:

- The take-off performance may be restricted by the fine adjustable pitch stop being at too high a setting, so preventing the engine from developing full take-off speed, and hence full take-off power.
- The cruise performance may be restricted by the coarse adjustable pitch stop being at too low a setting, so preventing a high power setting being used at the desired engine speed.

If performance is restricted due to the adjustable pitch stop settings of the propeller, then the stops may be adjusted, providing that the safety of flight requirements are still met. After each adjustment the flight tests to verify safety of flight should be repeated.

## Part 8.4. Adjustable Pitch Stops – Method of Adjustment

### Section 8.4.1. Introduction

The adjustable pitch stops are found within the motor cap, in the area also occupied by the pitch change motor. Each stop is formed by a cylindrical pitch feedback cam connected to the pitch change mechanism by a threaded pitch feedback rod. The pitch feedback cam actuates a pitch feedback microswitch within the propeller hub circuit wiring that controls the flow of electric power to the pitch change motor. By rotating the cam on its pitch feedback rod, the cam may be adjusted to actuate the microswitch at the desired propeller pitch.

### Section 8.4.2. Identification of Adjustable Pitch Stops

Each adjustable pitch stop is associated with a circuit identified by different coloured wiring and using a different one of the slip-rings. Each adjustable pitch stop may be identified by the circuit wiring colour of the associated microswitch (the each cam can be seen to be in contact with an associated microswitch). Each adjustable pitch stop and associated circuit wiring is also located in the area adjacent to a particular propeller blade. Each adjustable pitch stop has a slightly different adjustment rate associated with it due to the geometry of the pitch change mechanism. The three adjustable pitch stops are detailed in the following tables and diagrams (note there are differences between 2-bladed and 3-bladed propellers:

## 3-bladed propellers

Adjustable Pitch Stop	Circuit Wiring Colour	Slip-Ring Position	Location (near blade No.)	Approximate Adjustment Rate (degrees per full turn of the cam)
Fine Pitch	Black	Outer	1	1.8
Coarse Pitch	Red	Middle	2	1.7
Feather Pitch	Green	Inner	3	2.4
Beta Pitch	Blue	Inner	3	2.4

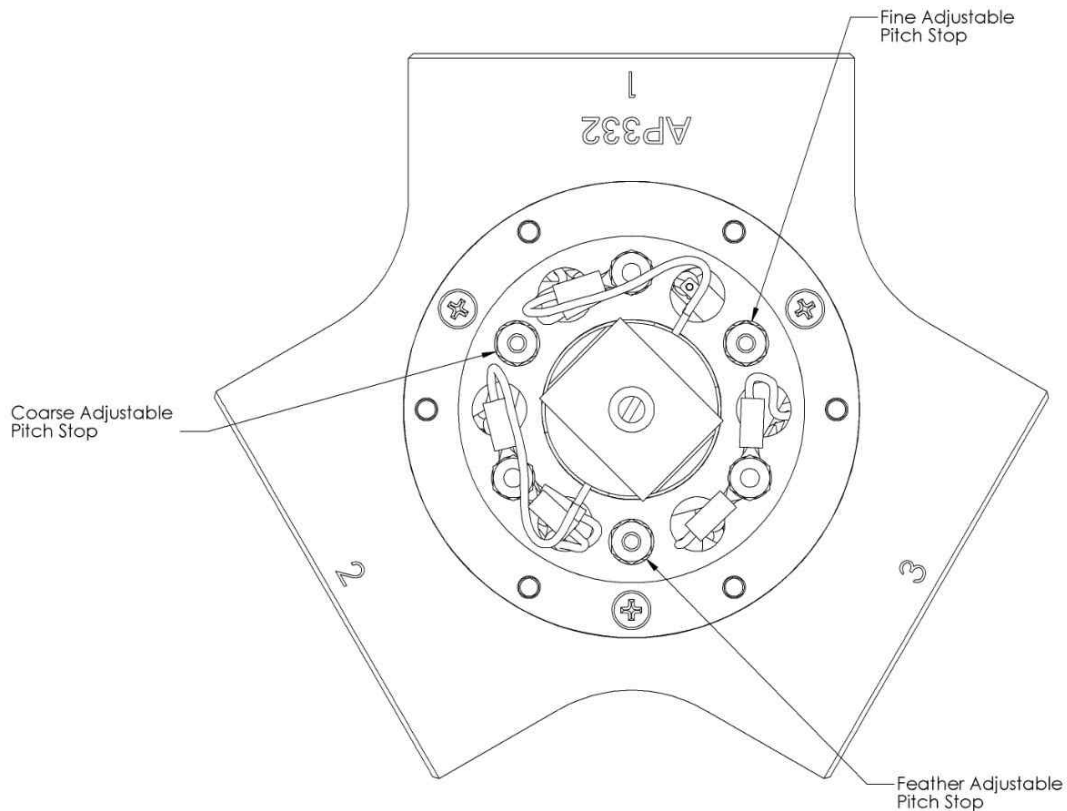

**Figure 18. Location of Adjustable Pitch Stops on 3 bladed Propeller Hub Assembly (AP332 shown)**

Note: For further detailed information about adjustable pitch stops and associated parts of the circuit within the propeller hub, cable and controller, see ANNEX C. Propeller Hub and Sensor/Brush Assembly Wiring.

## 2-bladed propellers

Adjustable Pitch Stop	Circuit Wiring Colour	Slip-Ring Position	Location (near blade No.)	Approximate Adjustment Rate (degrees per full turn of the cam)
Fine Pitch	Black	Outer	1	1.8
Coarse Pitch	Red	Middle	2	1.7
Feather Pitch	Green	Inner	2	2.4



**Figure 19. Location of Adjustable Pitch Stops on 2-bladed Propeller Hub Assembly (AP420 shown)**

Note: For further detailed information about adjustable pitch stops and associated parts of the circuit within the propeller hub, cable and controller, see ANNEX C. Propeller Hub and Sensor/Brush Assembly Wiring.

### Section 8.4.3. Method of Adjustment

Adjustment of the adjustable pitch stops is made by the following method:

**WARNING:** Before working on propeller, ensure that the engine is safe by turning ignition system off.

- a. Remove the spinner and spinner front support.
- b. Remove the motor cap. (The lock-wire through the fasteners holding this motor cap will need to be removed if the propeller has been in service.)

**Caution:** The engine and propeller should not be run with the motor cap removed from the propeller.

- c. Locate the correct pitch feedback cam. (The pitch change mechanism may have to be driven towards a finer pitch to enable access to the adjustment flats part of the cam. Use the manual control mode to do this.)
- d. Loosen the lock-nut above the pitch feedback cam with an 11/32in spanner.
- e. Adjust the position of the pitch feedback cam by applying a 5/16in spanner to the adjustment flats at its end. Rotate the pitch feedback cam so that it moves along the threaded pitch feedback rod in the desired direction:
  - i. The cam should be rotated clockwise (or in towards the hub) to decrease the pitch setting.
  - ii. The cam should be rotated anti-clockwise (or out away from the hub) to increase the pitch setting. Do not adjust the cam so far that there is insufficient room for the lock nut and a further 3.5mm(0.15in) of free threads on the rod.



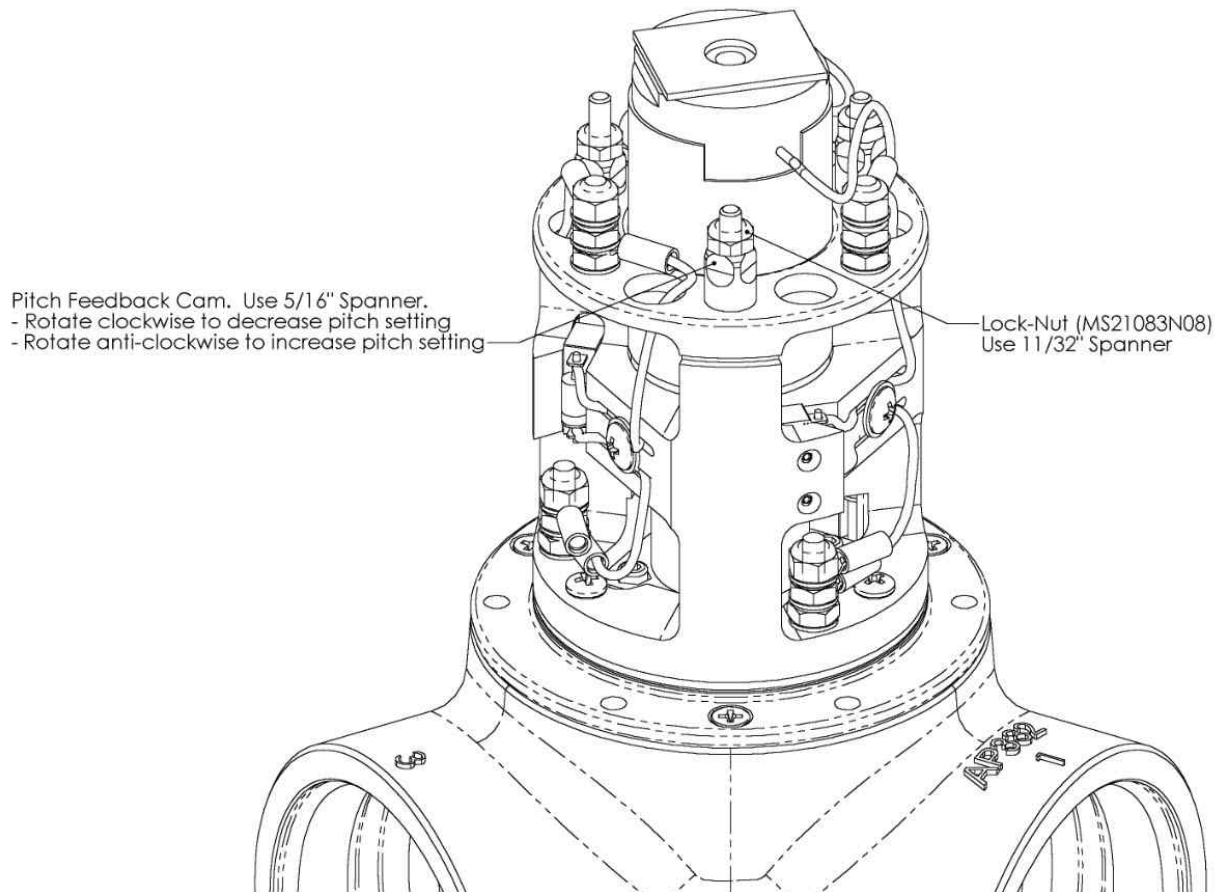

**Figure 20. Adjustment of Pitch Feedback Cam (AP332 shown)**

- f. Tighten the lock-nut against the pitch feedback cam, so that the cam and locknut are prevented from further rotation. Remember to hold the pitch feedback cam with the 5/16in spanner to prevent it moving from its set position.
- g. Alter the propeller pitch using the manual over-ride so that the propeller pitch travels to the newly set pitch stop. Ensure that the mechanism does not contact one of the two fixed pitch stops before reaching the adjustable pitch stop. A laboured sound from the pitch change motor and an over-current indication from the controller (applicable indicator illuminating red) will indicate this. If one of the hard stops is reached, then the adjustment has been made outside the design range. The adjustable pitch stop should be re-adjusted to bring it back within the design range.
- h. Refit the motor cap.
- i. Lock the six motor cap retaining screws with 0.025in lock-wire. The single-wire method of lock-wiring may be used for this application.

**Caution:** Do not fly the propeller without this lock-wire in place. However the lock-wiring may be omitted during ground testing of the propeller.

- j. Refit the spinner front support (if applicable) and spinner in accordance with Part 5.6, Spinner Installation.

#### Section 8.4.4. Techniques to Assist Adjustment to Desired Pitch Setting

While the previous section details the method used to physically adjust the adjustable pitch stops, it does not provide advice on where to adjust the pitch feedback cams to, in order to achieve the desired pitch setting. The following techniques may be used to assist adjustment to the desired pitch setting:

- If after a ground or flight test, the propeller pitch is left in a position desired for one of the pitch stops, the pitch feedback cam may be carefully adjusted until the applicable microswitch is actuated. To determine if the microswitch has been actuated, use one of the following methods:
  - In a quiet environment the microswitch may be heard to click as it is actuated.
  - With power applied to the controller and an observer in the cockpit of the aircraft, the indicators on the controller will indicate when the microswitch is actuated.
- The propeller may be adjusted by a small amount in increments, with the propeller tested between each adjustment. An adjustment of half a turn (or two flats) at a time should be suitable.

## CHAPTER 9. OPERATION OF AC200 SMARTPITCH CONTROLLER

Note: This chapter details the functions of the AC200 SmartPitch controller, its controls, its indications and possible failure modes. This chapter should be understood before first flight to gain familiarity with the controller. For step-by-step propeller operating instructions, refer to the CHAPTER 10, Operating Instructions.

### Part 9.1. Controls and Functions

#### Section 9.1.1. Introduction

The AC200 SmartPitch Controller is a constant speed propeller controller. The controller mounts in the aircraft instrument panel and incorporates the following controls:

- **Automatic/Manual Selector.** The automatic/manual selector selects between automatic (normal) operation of the controller and manual over-ride.
- **Propeller Control Selector.** The propeller control selector allows control while automatic operation is enabled. (This control has no function when manual over-ride is enabled.) The selector selects between various control modes and provides speed control when in the pre-set speed governing mode.
- **Feather Engage Switch (option).** The feather engage switch is used to initiate the automatic feather cycle of the controller.
- **Beta Engage Switch (option).** The beta engage switch is used to initiate the beta functions of the controller in combination with the AUTO/MAN switch.
- **Manual Control Switch.** The manual control switch allows direct control of the propeller pitch when manual over-ride is enabled. It has an additional function in automatic operation of setting the governed speed when the hold control mode is selected. The manual control switch is in a separate unit to the main control unit and may be mounted elsewhere in the cockpit.

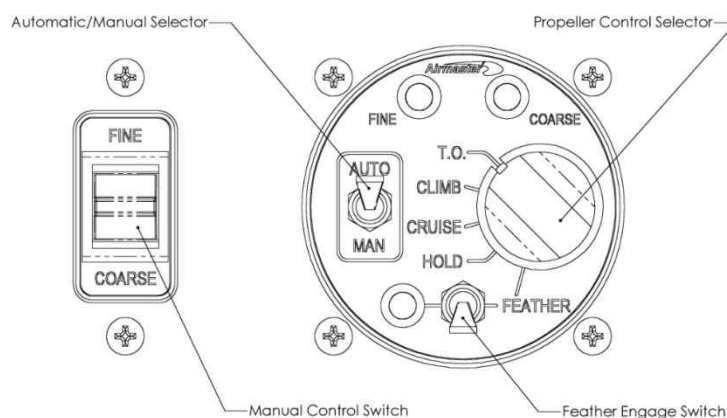

Figure 21. Controls of AC200 SmartPitch Controller (Feathering version shown)

### Section 9.1.2. Automatic/Manual Selector

The automatic/manual selector selects between automatic (normal) operation of the AC200 SmartPitch Controller and manual over-ride. It is a two position switch with the following positions:

- **AUTO.** AUTO position is used to enable the automatic (normal) operation of the AC200 SmartPitch Controller. Automatic operation includes constant speed governing in pre-set and hold modes, and feathering.
- **MAN.** MAN position is used to enable manual over-ride of the controller. In this operation the propeller functions as an in-flight adjustable variable pitch propeller using the manual control switch. All the automatic operation of the controller is bypassed, so that this position can be used in the event of a controller failure to maintain control of the propeller. When manual over-ride is enabled the manual control switch exercises direct control of the propeller. See the information below on the manual control switch for details of this operation.

### Section 9.1.3. Propeller Control Selector

When automatic operation is enabled on the AC200 SmartPitch Controller the propeller control selector selects between various control modes, and provides speed control when in the pre-set speed mode. The propeller control selector is coloured blue to conform to the standard identification for propeller controls. The selector is a rotary switch with selections corresponding to the control modes and speeds detailed below.

**Pre-Set Speed Governing Mode.** The pre-set speed governing mode provides constant speed propeller governing at any of three pre-set engine/propeller speeds. The propeller control selector allows selection of these three speeds as follows:

- **T.O.** The T.O. selection selects the take-off speed. Generally this will be the maximum speed permissible for the engine (less a margin), which will allow the maximum possible power to be produced. This selection is used for take-off and landing.
- **CLIMB.** The CLIMB selection selects the climb speed. Generally this will be the maximum continuous speed permissible for the engine (less a margin), which will allow sustained high power to be produced. This selection is used for climbing, and may be used for any other operation where continuous higher power settings are required.
- **CRUISE.** The CRUISE selection selects the cruise speed. Generally this will be a speed selected to match the engine, propeller, aircraft combination to give the best compromise between aircraft speed and economy. This selection is used for normal cruise operation.

The manufacturer programs the pre-set speeds of the controller as indicated in the leading particulars section of the propeller logbook. The standard speeds that the controller will normally be programmed with are indicated in the following table:

Aircraft Engine Type	Pre-Set Speeds (Engine Speed)			Engine Limitations	
	Take-Off (rpm)	Climb (rpm)	Cruise (rpm)	Maximum Speed (rpm) (5 mins max)	Maximum Continuous Speed (rpm)
Rotax	5700	5400	5000	5800	5500
Jabiru	3250	2900	2600	3300	

Note: The tachometers supplied with some engines are sometimes found to be inaccurate. If the governed speed appears to be different to that indicated in the propeller logbook, an independent check on the tachometer accuracy should be conducted before further investigation. A device such as a handheld optical tachometer may be used.

The AC200 SmartPitch controller can be programmed by using a personal computer with a USB serial connection. This enables the pre-set speeds and other operational parameters to be customised for any particular application. Contact the manufacturer for more information about this capability.

The controller will maintain the engine/propeller speed within certain governing limits (ie tolerance or normal deviation from set speed) of the programmed speeds. The governing limits are approximately as indicated in the following table:

Aircraft Engine Type	Governing Limits (rpm) (Engine Speed)
Rotax	Approximately $\pm 100$
Jabiru	Approximately $\pm 50$

- **HOLD** The hold speed governing mode provides constant speed propeller governing at a speed able to be set in flight by the pilot, and is selected by the HOLD selection. This mode is used when the pilot wishes to operate the propeller at a speed other than those provided by the three pre-set speeds. It may be used to set an ideal engine/propeller speed for cruise operation in particular conditions. When hold speed governing mode is selected, the manual control switch exercises speed control. See the information below on the manual control switch for details of this operation.

Upon application of power to the controller (ie at start-up of the aircraft) the initial hold speed programmed into the controller is set (by parameter 113). During operation in the hold speed governing mode the hold speed setting may be varied by the pilot using the manual control switch as detailed below. The most recent hold speed setting is retained in memory, even after any other control mode is selected, allowing the same hold speed setting to be returned to later in the flight. However the hold speed setting is reset to the pre-set value after power is removed from the unit (ie at shutdown).

The AC200 SmartPitch Controller is programmed with limits to the hold speed that can be set by the pilot. The standard hold speed limits that the controller will normally be programmed are indicated in the following table:

Aircraft Engine Type	Maximum Hold Speed (rpm) (Engine Speed)	Minimum Hold Speed (rpm) (Engine Speed)
Rotax	5700	4000
Jabiru	3000	2200

- **FEATHER. (option)** The feather mode, which is selected by the FEATHER selection, allows the propeller to be feathered in flight, and provides complete control of this process.

A two-step operation is required to feather the propeller to eliminate the possibility of inadvertent feathering. In this mode the pilot initiates the automatic feather cycle by momentarily actuating the feather engage switch. The propeller will then automatically move to the feather position. The automatic feather cycle takes 20 to 40 seconds depending on what pitch the propeller is at when the cycle is commenced and what pitch the feather pitch limit is set at.

The propeller may be un-feathered at any time by simply selecting any other position on the propeller control selector (ie the hold speed governing mode or one of the pre-set speed governing modes). The propeller will then automatically move to the flight range, and constant speed governing will commence as soon as a controllable engine/propeller speed is achieved.

See the information below on the feather engage switch for further details of feathering operation.

- **BETA (Option)** The beta mode, which is selected by the BETA selection, allows the propeller to be operated at pitch settings below the flight minimum set by the fine pitch stop.

A three-step operation is required to activate the beta operation to eliminate the possibility of inadvertent activation.

- Select AUTO/BETA

Note: Ensure the engine RPM is below the 'Max Engage RPM' (2000rpm for Rotax) (par #400)

- Activate the BETA engage switch
- Select MAN

The propeller may now be manoeuvred to any pitch within the beta range of approx -20deg to +40deg by means of the manual FINE/COARSE switch.

Note: Ensure the engine RPM is below the 'MaxRunRPM' (3500rpm for Rotax) (par #404) when moving toward the reverse pitch stop.

The propeller may be reverted to normal operation at any time by simply selecting AUTO/CRUISE. The propeller will then automatically move to the flight range, and constant speed governing will commence as soon as a controllable engine/propeller speed is achieved.

Note: It will take ~10 seconds for the completion of the Beta\_Exit cycle.

See the information below on the Beta engage switch for further details of Beta operation.

#### Section 9.1.4. Engage Switch (option)

The engage switch is used to control the special operations of the AC200 SmartPitch Controller and the propeller (Feather / Beta). The engage switch is a momentary switch actuated by lifting the switch to the up position, which returns to the down position when released.

#### Section 9.1.5. Manual Control Switch

The manual control switch allows direct control of the propeller pitch. It is a two-position momentary switch spring-loaded to the central or 'off' position, and is mounted in a separate unit that may be mounted elsewhere in the cockpit. The switch functions differently in automatic and manual over-ride operation as follows:

**Automatic Operation (HOLD).** The manual control switch is used when the AC200 SmartPitch Controller is in the hold speed governing mode. In any other automatic operation control mode the switch has no function. When actuated, the manual control switch causes the propeller pitch to change in the direction selected, resulting in a change in engine/propeller speed. The pitch will continue to change in the direction selected as long as the switch is held or until a pitch limit is reached. When released, the controller records the speed at that time, updates the hold speed setting and provides constant speed propeller governing to this new speed. This function allows the pilot to actuate and hold the switch, while observing the engine tachometer. When the desired speed is indicated, the pilot releases the switch. The two positions of the switch function as follows:

- **FINE.** Actuating the switch up to the FINE position results in the pitch moving to a lower (finer) setting, and a consequent increase in engine/propeller speed. Upon release constant speed governing to the new higher speed will then occur.
- **COARSE.** Actuating the switch down to the COARSE position results in the pitch moving to a higher (coarser) setting, and a consequent decrease in engine/propeller speed. Upon release constant speed governing to the new lower speed will then occur.

**Manual Over-Ride.** The manual control switch is used when the manual over-ride is enabled. When actuated, the manual control switch causes the propeller pitch to change in the direction selected, resulting in a change in engine/propeller speed. The pitch will continue to change in the direction selected as long as the switch is held or until a pitch limit is reached. The two positions of the switch function as follows:

- **FINE.** Actuating the switch up to the FINE position results in the pitch moving to a lower (finer) setting, and a consequent increase in engine/propeller speed.
- **COARSE.** Actuating the switch down to the COARSE position results in the pitch moving to a higher (coarser) setting, and a consequent decrease in engine/propeller speed.

Note: If the manual control switch is held at the COARSE position while feather engage switch is also actuated, the propeller pitch will continue to increase past the coarse pitch limit into the feather range. This allows the propeller to be feathered manually. When manual over-ride is enabled, any movement of the propeller pitch to a higher (coarser) setting while in the feather range requires both the switches to be actuated simultaneously.

## Part 9.2.           Indications

The AC200 Smart Pitch Controller incorporates indicator lights to show the current status of the propeller and control system. They are labelled; FINE, COARSE and FEATHER/BETA (option); and correspond to drive states of the controller and the pitch limits within the propeller.

Note:           ‘Pitch limit’ refers to that pitch setting determined by the applicable adjustable pitch stop. See CHAPTER 8, Set-Up of Propeller Pitch Stops.

The indicator lights are three-colour LEDs, and all operate with the following general meanings of their indications:

- **Orange.** The controller is driving the propeller pitch in the direction indicated.
- **Orange Flashing (FINE led).** The controller is receiving no speed signal and has ceased attempting to control the propeller. This signal will normally be observed on start-up when power has been applied to the controller but the engine has not yet been started. This indication is normal in this situation.
- **Green.** Propeller pitch is at or beyond applicable pitch limit.
- **Green Flashing.** Propeller pitch is at or beyond applicable pitch limit and the controller is attempting to drive the propeller pitch further in the same direction. (The pitch will not be driven in this direction due to action of the adjustable pitch stops in the hub.) This situation will occur when the propeller is unable to attain the desired governing speed due to a pitch limit being reached (eg when the throttle is closed and the propeller pitch at the fine pitch stop).
- **Red.** Propeller and controller are suffering an over-current situation while the propeller is being driven in direction indicated. This will normally be due to a defect in the propeller pitch change mechanism causing resistance to a change in pitch, or due to the propeller pitch reaching one of the fixed pitch stops due to incorrect adjustment of one of the applicable adjustable pitch stops.
- **Red Flashing (all led).** The propeller has suffered an open circuit failure of the propeller wiring or the pitch change motor, and the controller is unable to control the propeller pitch.
- **Rapid Red Flashing (all led).** The controller has experienced a fault with its software. This may be due to a problem with the controller software revision or the controller parameters.
- **Red Flashing (FINE led)** The fine pitch stop has been bypassed by the beta control circuits allowing the propeller pitch to be adjusted beyond the normal fine pitch limit.
- **Red Flashing (COARSE led)** The coarse pitch stop has been bypassed by the feather control circuits allowing the propeller pitch to be adjusted beyond the normal coarse pitch limit.



The following table lists the various status indications possible with the AC200 SmartPitch Controller:

Status of Propeller and Controller	Indicator Light		
	FINE	COARSE	FEATHER/BETA
Pitch decreasing	orange		
Pitch increasing		orange	
Pitch increasing in feather			orange
No speed signal	orange flashing		
Fine pitch limit	green		
Coarse pitch limit		green	
Feather pitch limit			green
Driving at fine pitch limit	green flashing		
Driving at coarse pitch limit		green flashing	
Driving at feather pitch limit			green flashing
Beta mode engage (step 1) (Beta option)	red flashing slow		
Fine pitch limit override (Beta option)	red flashing fast		
Coarse pitch limit override (Feather option)		red flashing fast	
Over-current while pitch decreasing	red		
Over-current while pitch increasing		red	
Over-current while pitch increasing in feather/			red
Open circuit failure	red flashing	red flashing	red flashing
Controller software fault	rapid red flashing	rapid red flashing	rapid red flashing

When manual over-ride is enabled (ie MAN is selected) many of the above indications will still occur. While the automatic functions of the controller are replaced by direct input from the pilot, the indication system continues to function, producing the same indications where applicable.

## Part 9.3. Failure Modes

### Section 9.3.1. Introduction

As with any electronic, electrical and mechanical system a variety of failures are possible. Possible failure scenarios of the AC200 SmartPitch Controller combined with an Airmaster propeller are listed here, with outlines of possible cause, symptoms, indications, specific actions and rectification required. Consult the manufacturer for assistance with any rectification.

Note: For immediate actions that should be followed in the event of any propeller control failure see Part 10.5, Emergency Operation.

### Section 9.3.2. Loss of Power

The propeller system may suffer a loss of power, such as a general failure of the aircraft electrical system, the tripping of the circuit breaker in the propeller supply or an incorrectly inserted power connector. In this event, no control of the propeller will be possible by either the controller or manual over-ride, and the propeller pitch will remain at its last setting. No indications will be observed on the controller. If the pitch limits have been set correctly, and the propeller pitch is in the flight range, then continued safe flight is possible. Control over the propeller will be regained upon restoration of power.

If the loss of power is as a result of the circuit breaker tripping, it is recommended that a single attempt be made to reset the circuit breaker, after a short period to allow the circuit breaker mechanism to cool down. Due to the risk of further damage or fire, do not attempt to reset the

circuit breaker more than once, unless this is required to maintain safe flight (such as when the propeller pitch is in the feather range).

### Section 9.3.3. Open circuit

The propeller system may suffer an open circuit failure, such as that due to a failed pitch change motor, a broken or worn slip-ring brush, a break in the wiring loom to the propeller, a break of the wiring within the propeller or an incorrectly inserted sensor/brush connector. In this event, no control of the propeller will be possible by either the controller or manual over-ride, and the propeller pitch will remain at its last setting. The controller will indicate this failure with all three indicators flashing red. If the pitch limits have been set correctly, and the propeller pitch is in the flight range, then continued safe flight is possible. Control of the propeller will not be possible until the failure is rectified.

### Section 9.3.4. Over-Current

The propeller system may suffer an over-current while changing pitch, such as that due to a defect in the pitch change mechanism causing resistance to a change in pitch, or due to the propeller pitch reaching one of the fixed pitch stops due to incorrect adjustment of one of the applicable adjustable pitch stops. In this event the controller will cease to drive the propeller pitch due to an internal current monitoring function, which temporarily disables the controller. The controller will indicate this failure with the indicator corresponding to the applicable drive direction illuminating red. Automatic operation of the propeller may be regained by resetting the controller, which is done by briefly selecting manual over-ride and then back to automatic. If automatic operation is not possible, control of the propeller may be achieved by enabling manual override. However manual over-ride control of the propeller should be minimised to avoid damage to the pitch change motor and mechanism. The failure that caused the over-current situation must be determined and rectified before next flight.

When manual over-ride is enabled, current is only limited by the aircraft electrical system circuit breaker in the propeller power supply. If the over-current situation remains, this circuit breaker may trip, resulting in a loss of power and control over the propeller. If the pitch limits have been set correctly, and the propeller pitch is in the flight range, then continued safe flight is possible. It is recommended that a single attempt be made to reset the circuit breaker, after a short period to allow the circuit breaker mechanism to cool down. Due to the risk of further damage or fire, do not attempt to reset the circuit breaker more than once, unless this is required to maintain safe flight (such as when the propeller pitch is in the feather range).

### Section 9.3.5. Short Circuit

The propeller system may suffer a short circuit failure, such as that due to an exposed wire in the wiring loom to the propeller. This failure will result in symptoms and controller behaviour as for an over-current. Neither automatic operation nor manual over-ride control will be possible, and attempts to control the propeller pitch manually may result in the propeller circuit breaker tripping. If the pitch limits have been set correctly, and the propeller pitch is in the flight range, then continued safe flight is possible. Control of the propeller will not be possible until the failure is rectified.

### Section 9.3.6. Controller Failure

The controller may suffer an internal failure. In this event automatic operation of the propeller may not be possible, or an unexpected change in propeller pitch may occur. The controller may show random indications, or no indications may be observed. Control over the propeller will be regained by enabling manual over-ride. The failure that caused the controller failure must be determined and rectified before next flight.

**Caution:** Should the controller fail such that an immediate and unexpected change in propeller pitch occurs, the engine/propeller speed will be observed to change. The pilot must monitor engine speed at all times and be prepared to change the throttle immediately to avoid limitations being exceeded. Control of the propeller should be regained immediately by enabling manual over-ride, and correcting the propeller pitch manually.

Some failures of the controller will result in the internal fuse (FS1) being tripped. In this event automatic operation will cease and no change to the propeller pitch will occur. No indications will be observed on the controller. Control over the propeller will be regained by enabling manual over-ride. The failure that caused the controller failure must be determined and rectified before next flight. The internal fuse may be reset on the ground by pushing the internal fuse button (FS1) on the rear of the controller. Do not carry out this action in flight.

### Section 9.3.7. Controller Software Fault

The controller may suffer a software fault, such as that due to a problem with the controller software revision or the controller parameters. In this event the controller will cease to drive the propeller pitch and no constant speed governing will occur. The controller will indicate this failure with all three indicators rapidly flashing red. Control over the propeller will be regained by enabling manual over-ride. The controller software fault must be determined and rectified before next flight.

Operation of the controller may be regained on the ground by resetting the controller. The controller can be reset by temporarily removing power from the controller using the circuit breaker, pushing the internal fuse button (FS1) or briefly switching off the aircraft power. Do not carry out this action in flight.

### Section 9.3.8. Loss of Speed Signal

The controller may suffer a loss of speed signal from the speed sensor, such as that due to a failure of the speed sensor, loss of the speed sense magnet, a failure of the speed sense wiring loom or an incorrectly inserted sensor/brush connector. In this event the controller will cease to drive the propeller pitch and no constant speed governing will occur. The controller will restore automatic operation if a stable speed signal is restored. Other automatic functions such as feathering will remain possible. The controller will indicate this failure with the fine indicator flashing orange. Control over the propeller will be regained by enabling manual over-ride. The failure that caused the loss of speed signal should be determined and rectified before next flight, however continued flight using manual over-ride is acceptable.

### Section 9.3.9. Failure of Manual Control Switch

The manual switch may suffer a failure, such as that due to a broken actuator, a failure of the manual control switch loom or an incorrectly inserted manual control switch connector. In this

event no manual over-ride operation or automatic operation in the hold speed governing mode will be possible. However automatic operation in all other modes will continue as normal. No particular indications will be observed on the controller. Control of the propeller should be continued with automatic operation. The failure of the manual control switch must be determined and rectified before next flight.

#### Section 9.3.10. Failure of Adjustable Pitch Stops Microswitches

The adjustable pitch stop microswitches may suffer a failure. If the microswitches fail open circuit then failure mode is as described above in Section 9.3.3, Open circuit.

If the microswitches fail closed circuit, then the adjustable pitch stops are rendered inoperative. In this event the propeller will be able to be operated beyond the setting of the applicable adjustable pitch stop (ie outside the flight range) due to normal operation by the controller or the pilot. If the propeller pitch is left outside the flight range, safe flight may not be possible in all situations.

Note: The propeller pitch will be limited by the fixed pitch stops at all times.

No indications other than normal will be observed on the controller, however if the propeller pitch is driven to one of the fixed pitch stops, then an over-current indication may be observed. If the pilot observes symptoms that indicate that the propeller pitch has been driven to a setting outside a normal range, such as an unusual combination of power, airspeed, and engine/propeller speed, then operation of the propeller should be continued using manual over-ride. The propeller pitch should be maintained in a normal range by reference to power, airspeed and engine/propeller speed. The failure of the adjustable pitch stop microswitches must be determined and rectified before next flight.

#### Section 9.3.11. Failure of Beta function stops.

The beta enabled hubs allow the blade pitch to be adjusted (in specific conditions) to angles beneath those which will sustain flight. As such they pose a greater risk than the standard hub types. Extra precautions have been taken with these hub types to mitigate these risks and are described below.

- a. **Pilot error-** The pilot may attempt to initiate the beta function during flight by mistake. Three separate actions would be required to do this. <select BETA><lift activation lever><select manual>. In this case the controller software is monitoring the engine rpm and will not engage the beta electrical circuit unless the engine speed is below a pre-set minimum which would not normally be encountered during flight.
- b. **Controller malfunction-** The controller may experience a fault that causes the beta circuit to energise. In this case beta action is prevented since it would require the pilot to purposefully drive the propeller into the beta range using the manual switch.
- c. **Electrical malfunction-** The fine pitch stop microswitch may suffer a failure. There is a second microswitch positioned ~2deg past the first switch that will operate. If the first microswitch fails open, then failure mode is as described above in Section 9.3.3, Open circuit. If it fails closed the mechanism will travel to the second microswitch and activate it.
- d. **2<sup>nd</sup> Electrical malfunction-** The second microswitch may suffer a failure along with the first microswitch. In this case there is a mechanical stop which will limit the pitch

travel. It is set at the same angle as the hard stop on the regular hub types. This stop is centrifugally engaged at engine speeds encountered during flight.

- e. **Hard stop malfunction-** The centrifugally actuated stop may suffer a malfunction.
  - i. Stop on- If it seizes in the activated position, operation in the beta region will not be possible. An over current will occur as the pitch mechanism is driven into the stop. Normal propeller operation will be possible in all other modes.
  - ii. Stop off- If it seizes in the inactive position, the propeller will rely on the first four systems to avoid beta pitch angles. These are pilot actuation, software gate, microswitch 1 and microswitch 2.

## CHAPTER 10. OPERATING INSTRUCTIONS

### Part 10.1. Introduction and Applicability

These instructions are supplementary to the flight manual and operating instructions of the aircraft and engine. They only cover the operational aspects of the propeller and should not override any instructions, cautions or warnings for any other equipment.

**Note:** For a detailed description of the AC200 SmartPitch Controller, its controls, its indications and possible failure modes, refer to the CHAPTER 10, Operation of AC200 SmartPitch Controller.

**Note:** The following notation will be used in these instructions to state the required position of the controls on the AC200 SmartPitch Controller:

<Automatic/Manual Selector> / <Propeller Control Selector>

eg AUTO/CLIMB means that the automatic/manual selector should be set to AUTO and the propeller control selector should be set to CLIMB.

### Part 10.2. General Handling

#### Section 10.2.1. Introduction

As the propeller is a variable pitch propeller, it must be handled differently to a conventional fixed pitch propeller. If used incorrectly the propeller can lead to engine limitations of manifold air pressure and speed to be exceeded in flight.

**Caution:** The propeller pitch is able to move to settings considerably coarser than typical fixed pitch propellers. Therefore the propeller may provide such a load on the engine that manifold air pressure (MAP) limits are exceeded. On aircraft with MAP limits, the pilot must ensure that the throttle is set so that MAP is kept within limits at the set engine speed.

The propeller is designed so that normal operation is automatic operation using the AC200 SmartPitch Controller. This operation provides constant speed governing of engine/propeller speed.

#### Section 10.2.2. Automatic Operation

Automatic operation is when the automatic/manual selector is set to AUTO. The propeller system then functions as a constant speed propeller, where the propeller pitch changes automatically to keep the engine/propeller speed at a set value. This operation greatly reduces the workload of the pilot. The pilot effectively sets the desired power setting with the throttle and is then able to fly the aircraft, while having confidence that the engine/propeller speed, and therefore the power output, will remain constant.

Engine power is usually set by adjusting the throttle to achieve the desired performance. On aircraft with a MAP gauge, the MAP indication may be used to set the desired power.

The pilot must remain aware of the governing capabilities of the propeller system. The controller and pitch change mechanism have a finite response time and a finite rate of pitch change. The system is able to respond to normal changes in airspeed or throttle settings so that the speed remains within the governing limits of the set speed. However rapid change in airspeed or throttle setting

will result in temporary deviations outside the governing limits until the propeller pitch is able to change sufficiently. Therefore throttle changes should be made in a slow and smooth manner.

**Note:** The governing limits (ie normal deviation from set speed) are detailed in CHAPTER 9, Operation of AC200 SmartPitch Controller.

At all times the engine speed should be monitored to ensure that limits are not exceeded. Should the engine speed be observed to increase above the maximum, the throttle should be reduced immediately to keep the engine speed within limits. The following events may result in such an over-speed:

- Failure of the controller.
- Sudden increase in airspeed such as would be experienced in a dive.
- Rapid increase in throttle while in flight.

### Section 10.2.3. Manual Over-Ride

If required the propeller may be operated in manual over-ride during any phase of flight. This is enabled by setting the automatic/manual selector to MAN. Manual over-ride is normally enabled in response to a failure of the automatic control system.

**Note:** See Part 9.3, Failure Modes, for a description of possible failure scenarios.

In manual over-ride the pilot has complete and direct control over the propeller pitch using the manual control switch. The pilot must control the propeller pitch and engine throttle to give the desired combination of power and engine speed, and to achieve the desired performance.

**Caution:** An over-speed situation must be avoided. Selection of too fine a propeller pitch for the power setting will result in an over-speed.

**Caution:** Excessively low engine speed must be avoided. Selection of too coarse a propeller pitch may result in the engine being unable to maintain the desired engine speed even at full throttle.

## Part 10.3. Functional Checks and Procedures

### Section 10.3.1. Introduction

The correct function of the propeller must be verified before flight. The functional checks and procedures in this part are designed to establish that the propeller is serviceable and ready for flight.

**Note:** Consideration should be given to adding these checks and procedures to the aircraft checklist.

### Section 10.3.2. Pre-Start Check (Feathering)

**Note:** The pre-start check is optional for most flights. The pre-start check is necessary if feathering (ie gliding flight) is intended. Consideration should be given to conducting this check at intervals, to work the pitch change mechanism through its range of travel, and ensure good distribution of lubrication.

The following steps should be added to the pre-start checklist (as required for gliding flight):

- a. Select AUTO/FEATHER.
- b. Initiate the automatic feather cycle (momentarily use the feather engage switch). Ensure that the propeller pitch moves smoothly to the feather position. Ensure that the feather indicator illuminates orange while the propeller pitch increases and then illuminates green when the feather pitch limit is reached.
- c. Select AUTO/CRUISE. Ensure that the propeller pitch moves smoothly to the flight range. Ensure that the fine indicator illuminates orange while the propeller pitch decreases.

### Section 10.3.3. Starting

The following steps should be added to the start sequence:

- a. Select MAN.
- b. Drive the propeller pitch to the fine pitch limit (indicated by fine indicator illuminating green).
- c. Start the engine using the normal procedure.

### Section 10.3.4. Engine Run-Up and Pre-Take-Off Check

The following steps should be added to the engine run-up and pre-take-off check. The engine should be warmed up before this check in accordance with normal requirements:

- a. Set normal engine run-up speed.
- b. Select MAN.
- c. Drive the propeller pitch toward coarse. Ensure that the coarse indicator illuminates orange and the engine/propeller speed decreases.
- d. Drive the propeller pitch toward fine. Ensure that the fine indicator illuminates orange and the engine/propeller speed increases.
- e. Select AUTO/CRUISE.
- f. Ensure that the no speed signal indication (fine indicator flashing orange) is **not** observed.

**Note:** The next part of the engine run-up and pre-take-off check is not mandatory, and may be omitted if desired.

**Caution:** The next part of the engine run-up and pre-take-off check requires a high power setting. Ensure that brakes are set and holding, area in front of aircraft is clear, and that engine indications are within limits.



- g. Increase throttle smoothly until cruise pre-set speed is reached. Ensure that governing occurs (ie propeller pitch increases and fine indicator extinguishes) and that speed is held at cruise pre-set speed if throttle is increased further.
- h. Reduce throttle smoothly. Ensure that propeller pitch decreases to the fine pitch limit (indicated by fine indicator illuminating green).

## Part 10.4. Flight Operations

### Section 10.4.1. Introduction

As outlined in general handling, a constant speed propeller allows the pilot to set the desired power setting and fly the aircraft. However for different flight regimes the most appropriate governing speed must also be set, to ensure that the desired power setting may be effectively achieved.

The following guidelines are provided for the use of an Airmaster propeller with the AC200 SmartPitch Controller. These are recommendations only on the effective use of the constant speed capabilities of the propeller system, and may be varied to suit desired operations.

**Note:** Consideration should be given to adding these instructions to the aircraft flight manual.

### Section 10.4.2. Taxi

Taxiing may be carried with the propeller at any setting, however if cooling on the ground is limited, and engine temperature becomes high, consideration may be given to increasing the pitch of the propeller. By selecting MAN, and driving the propeller to a coarser pitch, the blade angle will be increased, therefore enhancing the cooling flow from the propeller.

### Section 10.4.3. Take-Off

Select AUTO/T.O. Smoothly increase the throttle to full power. Take-off and climb to the point of normal after take-off checks (recommend no lower than 500ft AGL).

**Caution:** Take-off speed may be higher than the maximum continuous speed of the engine. The time limit for operation above the maximum continuous speed should be observed if applicable.

### Section 10.4.4. Climb

Select AUTO/CLIMB. Set climb power with the throttle. In many situations, such as after take-off, this will be full power.

### Section 10.4.5. Cruise

Select AUTO/CRUISE. Set desired cruise power with the throttle.

### Section 10.4.6. Hold Speed Governing Mode

Select AUTO/HOLD. Use manual control switch to alter set speed. Set desired cruise power with the throttle.

Situations may arise where the pilot wishes to operate at a different speed to the pre-set governing speeds referred to in the above sections. The hold speed governing mode may be used to set an alternative engine/propeller speed. Typically this mode would be used in the cruise to achieve results such as a more fuel-efficient power setting or a higher than normal cruise speed.

When selecting AUTO/HOLD. The propeller will govern to the current hold speed setting . Use the manual control switch to change the hold speed setting as desired. While the manual control switch is actuated the propeller pitch will alter in the direction indicated, resulting in a corresponding change in engine/propeller speed. When the desired speed is indicated on the engine tachometer, release the manual control switch. The engine/propeller speed will then be governed to that speed. Finally, set desired power with the throttle.

#### Section 10.4.7. Feathering (Option)

Feathering the propeller is used to increase the glide performance of the aircraft. This function may be used when it is intended to conduct gliding flight (eg in a motor-glider), or in an emergency as a result of engine failure.

**WARNING:** Restoration of powered flight after feathering takes a finite time, and may not be possible due to a failure of the engine, propeller or aircraft electrical system. Any decision to feather the propeller must be made with safety of flight as the primary consideration. The aircraft should remain with gliding distance of a safe landing site at all times.

**Feathering.** Before feathering ensure that there is sufficient altitude to un-feather the propeller, re-start the engine, and achieve a positive rate of climb. Use the following procedure to feather the propeller:

- a. Select AUTO/FEATHER.
- b. Reduce the throttle to a low setting, and allow engine temperatures to stabilise as for a normal shutdown.
- c. Simultaneously shut engine down and initiate automatic feather cycle by actuating the feather engage switch.

Note: The actual order of engine shutdown and feather is not critical. A technique of initiation of the feather cycle shortly before final engine shutdown may be used to expedite completion of the feather cycle.

- d. The automatic feather cycle will then complete, with the feather indicator illuminating orange and the propeller pitch moving to the feather position. The coarse indicator will flash red at 5Hz 75% to indicate the coarse pitch stop is no longer active. The feather indicator will illuminate green when the feather cycle is complete.

**WARNING:** During gliding flight in most aircraft, management of electrical load on the battery will be a consideration. As the controller consumes very little power when not changing pitch (less than 0.2A, probably less than that consumed by lights or radios), the manufacturer recommends that the controller remains powered at all times to allow immediate un-feathering when required. Pilots must be aware that the electrical power is required to un-feather the propeller.

**Un-Feathering.** Un-feathering may take place at any time after the automatic feather cycle has been initiated (even before the automatic feather cycle has finished). Use the following procedure to un-feather the propeller.

- a. Select AUTO/CLIMB.
- b. The propeller pitch will then move towards the flight range, with the fine indicator illuminating green. The coarse indicator will flash red to indicate the coarse stop is not currently active.
- c. At completion of the un-feather cycle (or before), start the engine using the normal procedure.

**Note:** Typically the engine will successfully start once the propeller pitch has reduced to a point where normal idle speed can be achieved. (Typically this may occur after approximately 20 seconds of un-feather time.) After engine start at this point, the propeller will continue to un-feather to the flight range. This procedure may be used to minimise the total time to un-feather the propeller and restore powered flight.

- d. Smoothly increase the throttle to climb power.

**Emergency Feathering.** In the event of an engine failure, the propeller may continue to windmill due to the airflow, causing adverse drag. Feathering may be used to stop the windmilling, and to extend the engine out range. The following emergency procedure may be used to feather the propeller after attempts to restart the engine have been unsuccessful:

**Caution:** The pilot should be aware that a feathered propeller is less likely to break if it hits the ground, as it is stronger in this orientation. In this a situation, the impact of the propeller with the ground may cause the aircraft to tip over. In the event of a forced landing where a propeller blade may dig into the landing surface due to an undercarriage failure or the like, consideration should be given to leaving the propeller unfeathered.

- a. Select AUTO/FEATHER.
- b. Initiate automatic feather cycle by actuating the feather engage switch.

#### Section 10.4.8. Before Landing Check

The following steps should be added to the before landing check (eg the C.U.P. check; cowl flaps, undercarriage, propeller):

- a. Select AUTO/T.O.
- b. Ensure that propeller pitch is at the fine pitch limit (indicated by fine indicator illuminating green).

#### Section 10.4.9. Landing

Selection of AUTO/T.O. during the before landing check ensures that maximum performance is available in the event of a balked landing (go-around). In this event smoothly increase the throttle to full power as for a take-off.

### Section 10.4.10. Beta (Option)

Beta functions allow both forward and backward thrust from the propeller. This is designed to aid water manoeuvring for amphibious aircraft.

**WARNING:** Beta functions are not to be used for any other purpose than ground manoeuvres. It is expressly forbidden to attempt to use this function for short field landings or at any time while the aircraft is airborne.

**Entering Beta Mode.** Utilise the following procedure to access Beta functions:

- a. Reduce the throttle to an idle setting.
- b. Select AUTO/BETA.
- c. Actuate the Beta engage switch. You should observe the FINE indication light flashing red at 1Hz 10% duty.

**Note:** If you are unable to initiate the Beta cycle, check that the RPM is below the maximum allowed by the controller for this process. (For the Rotax 912S, this is 2000rpm)

- d. Switch the AUTO/MAN switch to MAN. You should observe the FINE indicator light flashing red at 5 Hz 75% duty. This signifies the fine pitch stop is no longer active.

**Note:** If you are unable to initiate the Beta cycle, check that the RPM is below the maximum allowed by the controller for this process. (For the Rotax 912S, this is 3500rpm)

- e. You may now use the FINE/COARSE switch to position the blade angle anywhere in its full range. The BETA pitch indicator light will indicate movement toward the reverse pitch stop and the COARSE indicator light will indicate movement toward the coarse pitch stop.
- f. It is suggested that the engine rpm be held at ~ 3000rpm and the pitch adjusted as necessary to allow precise control of the aircraft while docking.

**Note:** You can only adjust the pitch of the propeller in the reverse direction when the rpm is below 3500rpm. If the rpm rises above this value, reverse movement will be locked out until the rpm is lowered below this value.

**WARNING:** The aircraft must remain on the ground/water at all times while Beta operation is active.

**Caution:** During BETA operation, the controller will not play any part in the regulation of the engine speed. It is up to the pilot to ensure the engine speed is held within manufacturers specifications at all times.

**Caution:** During BETA operation there could be reduced airflow through the engine, and therefore reduced engine cooling. It is up to the pilot to ensure engine temperatures are monitored carefully at all times.

**Exiting Beta mode.** Use the following procedure to exit Beta mode and resume normal operation.

- a. Select AUTO/CLIMB.
- b. The propeller pitch will then move towards the flight range, with the COARSE indicator illuminating orange.
- c. At completion of the BETA exit cycle, normal automatic operation will resume and the FINE indicator will cease flashing red.

#### Section 10.4.11. Flight in Special Conditions

When flying at low altitude, low speed, in mountainous terrain or in any other situation where the sudden application of power may be required, consideration should be given to operating the propeller with the AUTO/CLIMB or AUTO/T.O. selected. These settings allow the engine to produce high power immediately.

## Part 10.5. Emergency Operation

A variety of failures that may lead to incorrect operation of the propeller are possible. These failure modes will typically affect the ability of the controller or the pilot to control the propeller.

Note: For a detailed analysis of possible failure modes, including possible cause, symptoms, indications, specific actions and rectification required, see Part 9.3, Failure Modes.

Symptoms of failure may include:

- A change in engine/propeller speed during a change in power or airspeed, with no associated response from the controller.
- No indications on the controller.
- Fine indicator light flashing orange.
- One indicator illuminating red.
- All indicators flashing red.
- All indicators rapidly flashing red.
- Sudden and unexpected change in engine/propeller speed.

**The following immediate actions should be followed in the event of any propeller control failure:**

- a. If required, immediately reduce throttle to avoid engine speed limitations being exceeded.
- b. Select MAN.

- c. Continue with manual over-ride operation of the propeller if this is possible. Use the manual control switch to control the propeller pitch, and set the engine throttle to give the desired combination of power and engine speed.

**Caution:** An over-speed situation must be avoided. Selection of too fine a propeller pitch for the power setting will result in an over-speed.

**Caution:** Excessively low engine speed must be avoided. Selection of too coarse a propeller pitch may result in the engine being unable to maintain the desired engine speed, even at full throttle.

- d. If manual over-ride operation of the propeller is not possible, the propeller pitch will remain at its last setting. If the propeller has failed with the propeller pitch in the flight range, flight may be continued with caution. The throttle should be used to control the engine/propeller speed and power as with a fixed pitch propeller.

**Caution:** If the propeller pitch is at a position other than the fine pitch limit, the pilot should note that full power may be unavailable at low airspeeds. Consideration of this must be made during approach and landing.

**WARNING:** If the propeller pitch is outside the flight range (such as may occur if the failure occurs during feathering), insufficient power may be available to sustain safe flight. A landing site should be selected immediately.

## CHAPTER 11. INSPECTION, MAINTENANCE AND REPAIR

### Part 11.1. Introduction

The propeller is to be maintained on an on-condition basis. The condition of the propeller is monitored by a combination of pilot monitoring during operation and regular inspection as detailed below.

The propeller contains no life-limited parts.

### Part 11.2. Inspection

#### Section 11.2.1. Pre-Flight Inspection

Before each flight conduct the following inspection:

- a. Inspect general condition of propeller assembly.
- b. Inspect all blades at leading edge for impact damage. Damage over 6mm(1/4in) long or 3mm(1/16in) deep is not acceptable. Any damage penetrating the leading edge erosion protection strip (if fitted) is not acceptable.
- c. Inspect root end of each blade for signs of cracking, dents, delamination and distortion. No damage is acceptable in this area.
- d. Check the assembly of each blade:
  - i. Apply a moderate torque by twisting with one hand only and monitor the movement produced. No movement should be evident between the blade and the ferrule into which it is mounted. A slight perceptible movement between the ferrule and the hub is acceptable, which is due to backlash in the pitch change mechanism.
  - ii. Apply a moderate force to the end of the blade with one hand only and monitor the movement produced. Ignore the deflection due to the bending of the blade itself. No movement should be evident between the blade and ferrule into which it is mounted. A slight perceptible movement between the ferrule and the hub is acceptable.

Note: The reduction gearbox on the Rotax engines has a discernible backlash. Do not confuse this backlash with movement of the blade within the hub.

- e. Inspect lock-wiring of bolts retaining propeller to propeller flange.
- f. Inspect spinner for correct attachment to spinner back-plate.
- g. Inspect sensor/brush assembly for intact brushes, and full contact with the slip-rings.

### Section 11.2.2. Periodic Inspection and Lubrication (At First 25 Hours, First 50 Hours, First 100 Hours and Subsequently at 100 Hour Intervals)

At the first 25 hours, first 50 hours, first 100 hours and subsequently at 100-hour intervals; conduct the following cleaning, inspection, greasing and reassembly:

**WARNING:** Before working on propeller, ensure that the engine is safe by turning ignition system off.

**Note:** As detailed below, consideration should be given to repeating this periodic inspection and lubrication at more frequent intervals, if necessary to ensure that the components are protected from moisture and well lubricated at all times.

**Note:** There are two different configurations of spinner front support. If the support is mounted to the motor cap by a screw thread, leave front support in place. If the front support is a loose part, remove and retain front support with spinner.

#### Cleaning

- a. Remove the spinner and the spinner front support (if applicable) from the propeller assembly. Check the spinner for cracking. No cracking is acceptable.
- b. Inspect the propeller hub for cracking or corrosion. Heavy corrosion or any cracking is unacceptable. Light corrosion may be removed and the surface protected.
- c. Inspect lock-wiring and locking of all external fasteners on propeller assembly.
- d. Inspect sensor/brush assembly and slip-rings on the spinner back-plate for wear. Ensure that slip-ring surface remains smooth, and that brushes are pressed by their springs onto the slip-ring surface correctly.
- e. Remove blade assemblies from the propeller hub as follows:
  - i. For the 3-series, loosen the four 10-32UNF set-screws that lock the blade assembly until they protrude approximately 4mm (3/16in) from the blade assembly retention nut, and then using the special blade assembly spanner that is provided, unscrew the blade assembly retention nut.
  - ii. For the 4-series, cut lock wire and remove 2 screws from retention plate, withdraw retention plate and then using the C-spanner, unscrew the blade assembly retention nut.

**Note:** Do not remove blades from the ferrules. This assembly is manufactured in a blade set-up jig, and such action would require that the blade angle be set-up again.

- f. Clean dirt and remove excess grease from blade assemblies, bearings and the blade assembly mounting bores in hub.
- g. Ensure that the propeller hub and blade assemblies are dry. Inspect all internal areas for evidence of water that may have entered the hub or moisture that may have collected due to condensation. If water is present, blow or wipe off excess water and allow remaining moisture in the assemblies to evaporate in a warm and dry area.



**Caution:** The presence of moisture is very dependent on the environmental conditions experienced by the propeller. Moisture can create the conditions for corrosion, which may damage components such as the blade bearings. If moisture or any evidence of corrosion is detected, consideration should be given to repeating this periodic inspection and lubrication at more frequent intervals to ensure that the components are protected from moisture and well lubricated at all times.

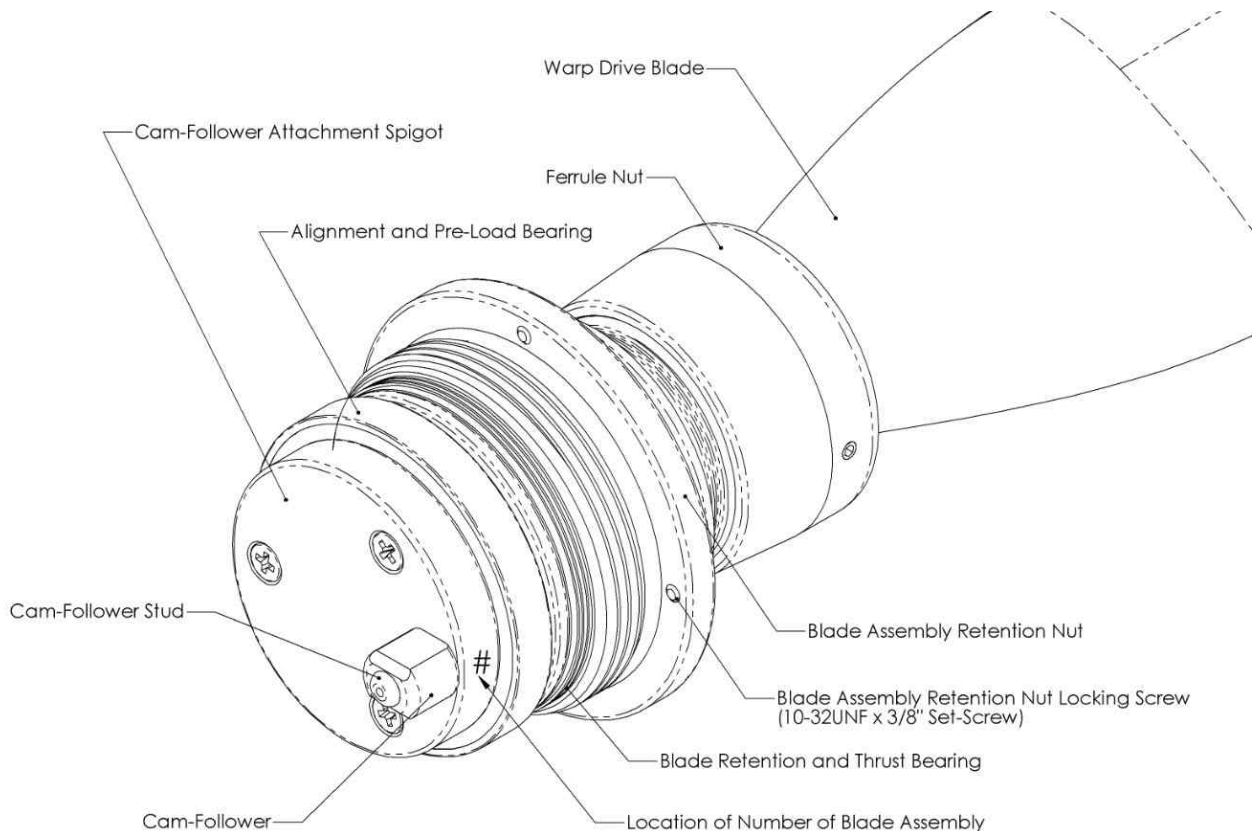

**Figure 22. Blade Assembly (AP332 shown)**

### Inspection

- h. Inspect the blade ferrule for cracking or corrosion. No damage is acceptable. Pay particular attention to the fillet area between the flange at the inner end of the ferrule and the main cylindrical section of the ferrule, as this is the principal load bearing area. Inspect this area closely under good illumination.

**Note:** This area of the ferrule may be seen by sliding the blade assembly retention nut, the blade retention and thrust bearing, and the aluminium spacer towards the outboard end of the ferrule. After wiping away excess grease, the fillet area to be inspected will be exposed. A matt finish will be observed on the area, where the surface has received a shot peen treatment to enhance its fatigue properties.

**Note:** It is normal to see some wear on the surface of the ferrule, under the retention bearing position. This is acceptable so long as there is no evidence of cracking emanation from this position.

- i. Inspect the blade assembly retention nut for cracking or corrosion. No damage is acceptable
- j. Slide the blade retention nut outboard along the ferrule towards the ferrule nut. Separate the three elements of the blade retention and thrust bearing (the two thrust washers/races and the cage complete with needle rollers).
- k. Inspect the blade retention and thrust bearing for damage. Broken rollers, indentations on the races, corrosion (other than minor staining) or obvious rough running are unacceptable, and are cause for bearing replacement.
- l. Inspect the alignment and pre-load bearing for damage. Corrosion (other than minor staining) or obvious rough running are unacceptable, and are cause for bearing replacement.
- m. Inspect the three blade assembly mounting bores in the propeller hub for damage such as cracking or corrosion to the threads or bearing surfaces. No damage is acceptable in this area.
- n. Inspect the pitch change mechanism within the propeller hub for loose components or obvious distortion.

#### Greasing

- o. Grease each Hub Bore and each Blade Assembly in accordance with Airmaster Service Letter SL-01.0 "Greasing Procedure for Airmaster Propellers"

#### Re-assembly

- p. Reassemble each blade assembly into its matching bore in the propeller hub in accordance with the instructions in Part 5.5, Assembly of Blades to Propeller Hub.
- q. Refit the spinner front support (if applicable) and spinner in accordance with Part 5.6, Spinner Installation.
- r. Conduct an engine off functional check of the propeller in accordance with Part 6.1, Engine Off Functional Check.

## **Part 11.3. Maintenance**

### Section 11.3.1. Replacement of Leading Edge Erosion Protection Strip

Airmaster generally only supply blades that have a built in leading edge protection. If it is deemed necessary to replace the leading edge protection, the blades will require demounting from the retention assemblies, and sending to the blade manufacturer for repair. Sometimes small nicks in the leading edge can be filled without removal. In these cases, please reference the blade manufacturer's instructions on blade care.

### Section 11.3.2. Replacement of Slip-Ring Brushes

The sensor/brush assembly brushes that run on the slip-ring will progressively wear down, as they act on the slip-rings. Once they have become so worn that the spring behind them is at full

extension, they will no longer have good contact with the slip-ring. This may be observed during an inspection of the propeller, or may become apparent as a result of an open circuit failure of the pitch change mechanism (indicated by all three controller indicators flashing red). To replace the brushes, follow the following procedure:

**Note:** Brushes are available from the manufacturer as a spare part (AP-P-0265).

- a. Remove the sensor/brush assembly from the engine. This may be achieved by either of the following two methods, depending on what is most convenient:
  - Remove the block with the brushes and sensor from its mounting bracket by removing the four countersunk screws, and carefully sliding the block from between the bracket and the slip-ring assembly. Insert a piece of card between the brushes and the slip-rings to protect the brushes.
  - Remove the complete assembly, including the mounting bracket from the engine. This is the reverse of the process used to install the assembly. Then remove the block with the brushes and sensor from its mounting bracket by removing the four countersunk screws.
- b. De-solder the three brush leads from the large pads (1, 2 & 3) on the circuit board, and remove the brushes from the front of the block. Clear old solder from pad.
- c. Insert new brushes from the front of the block, carefully guiding their braided leads through the holes in the circuit board.
- d. Pull leads through hole so that the brush just starts to compress the spring, and the lead is just taut (the brush should protrude approximately 12mm(0.5in) from the block). Bend the lead across the face of the solder pad and temporarily secure.
- e. Solder leads to solder pad with high quality electrical solder.
- f. Clip off excess lead close to the circuit board. Ensure that no part of the solder joint or the leads can contact on the bracket and cause a short circuit.
- g. Reassemble the sensor/brush assembly to the engine in the reverse order of the removal process. Ensure that the four countersunk screws are installed with medium strength thread-locking compound such as Loctite 243 (clean old compound from the holes). If the complete assembly including the bracket was removed from the engine, refit this assembly in accordance with the installation instructions in Section 5.7.4, Sensor/Brush Assembly.
- h. Check that no electrical continuity exists between the brushes and the sensor/brush mounting screws, by using a resistance meter. (Resistance should be greater the 1K $\Omega$ .)

## **Part 11.4. Repair**

Should any damage or unacceptable condition be detected during inspection or maintenance, advice of the manufacturer must be sought. The manufacturer may offer advice for repair in the field, or require that the propeller assembly be returned for repair.

**Caution:** Any type of ground strike will be considered an unacceptable condition.

## Part 11.5. Removal

In the event that the propeller must be removed from the engine, the following procedure should be used.

Note: The propeller should only be opened in a clean dry atmosphere and should not be left opened when exposed to the elements where moisture or dirt could enter the hub mechanism.

- a. Remove spinner cone by removing the securing screws (P0150) and fibre washers (P0175).
- b. Loosen propeller on engine propeller flange
  - i. Sequentially release (in increments) the six mounting bolts that secure the propeller to the engine propeller flange. Do not remove the bolts but retract them ~3mm (1/8in).
  - ii. Confirm that the propeller hub can be loosened from the flange.

Note: If it is tight (due to close tolerances and assembly compound), wriggle the propeller using the blades (held up to 1/3 the way along the blade) and or the motor cap.

**Caution:** Do not apply excess force by levering on the tip of the blade, or by striking the mounting bolts.

- iii. Re-tighten the mounting bolts enough to hold the hub firmly on engine propeller flange.
- c. Remove blade assemblies from hub

Note: The propeller can be removed with the blades installed, but this is not recommended as they are more difficult to remove once the propeller is not secured.

- i. Remove securing mechanism.
  - (a) 3 series
    - (i) Retract the four 10-32UNC set screws (P0119) so they sit proud of the retention nut by ~4mm (3/16in) using a 3/32 hex key.
    - (ii) Fit retention nut spanner on to two of the set screws. Use one hand to apply force to the spanner and the other hand to hold spanner onto the retention nut
  - (b) 4 Series
    - (i) Remove the retention nut securing plate (P0442) and two 10-32 screws (P0107).

- (ii) Fit retention nut spanner into the holes of the retention nut. Use one hand to apply force to the spanner and the other hand to hold spanner onto the retention nut.
- ii. Unscrew retention nut by two turns
- iii. Pull blade assembly outward while wiggling it to release the alignment bearing (you should hear a small clunk when this happens.)
- iv. Continue to unscrew retention nut and withdraw blade assembly from hub.

**Note:** The blade assembly will have grease around the retention bearing area. Make sure you have a clean place to place the blade assembly, and some way of protecting the bearing area from being contaminated with dirt. (Cling film can be useful for wrapping the bearing assembly for this purpose.)

- v. Repeat this process for each blade assembly.

**Caution:** If the installation uses the Rotax minislipping, the next part of the procedure is best performed with two people.

- d. Remove propeller hub from engine propeller flange
  - i. Standard slipping installations
    - (a) Remove the six bolts securing the propeller to the engine propeller flange.
    - (b) Withdraw the propeller hub from the engine propeller flange (being careful not to damage the carbon brushes in the brush block.)
  - ii. Rotax mini-slipping installations

**Note:** The next part of the procedure is best performed with two people.

- (a) Remove the six bolts securing the propeller to the engine propeller flange.
- (b) Withdraw and support the propeller hub (1<sup>st</sup> person)
- (c) Carefully remove the white heat-shrink from around the electrical connections (2<sup>nd</sup> person).
- (d) Separate the electrical connections between the hub and slipping.

**Note:** Take precautions when handling and storing the propeller hub so that dirt and moisture are kept out of the internal mechanism

## **Part 11.6. Overhaul**

When the propeller reaches 2000hrs it must be returned to the factory for overhaul. Overhaul of Airmaster propellers can only be performed by Airmaster Propellers Ltd, New Zealand.

#### Section 11.6.1. Overhaul Instructions

No overhaul instructions are currently available. Overhaul must be performed by Airmaster Propellers Ltd.

#### Section 11.6.2. Overhaul tooling.

No overhaul tooling is currently available. Overhaul must be performed by Airmaster Propellers Ltd.

#### Section 11.6.3. Training required

No training for overhaul is currently available. Overhaul must be performed by Airmaster Propellers Ltd.

#### Section 11.6.4. Overhaul Inspections

No overhaul inspections are currently available. Overhaul must be performed by Airmaster Propellers Ltd.

#### Section 11.6.5. Overhaul sequence

No overhaul sequence is currently available. Overhaul must be performed by Airmaster Propellers Ltd.

#### Section 11.6.6. Testing Requirements

No testing requirements are currently available. Overhaul must be performed by Airmaster Propellers Ltd.

#### Section 11.6.7. Mandatory Replacement Intervals

No mandatory replacement intervals exist. Only inspections Section 11.2.2 and checking of brush wear Section 11.3.2 are required.

### **Part 11.7. Shipping and Storage**

The original packaging containers and materials should be used whenever the propeller is to be shipped or stored. It is recommended that all original packaging be retained for future occasions requiring shipping or storage.

**ANNEX A.**

**PRINCIPAL DIMENSIONS OF PROPELLER INSTALLATIONS**

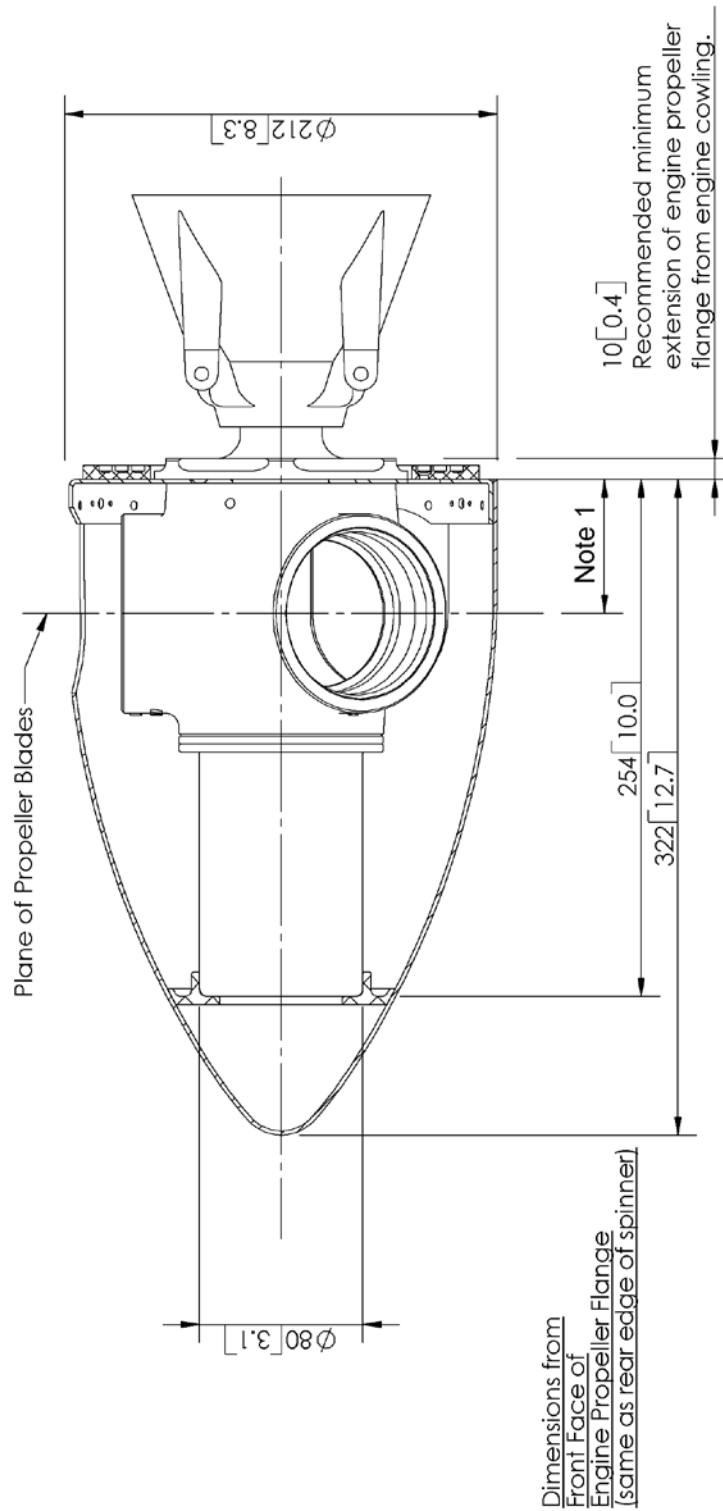

Principal Dimensions of AP332 Propeller with  $\phi 212\text{mm}$  (8.3in) Spinner  
 (Example shown mounted on Rotax engine)

Primary dimensions in millimeters [secondary dimensions in inches]

Note 1: Dimension 66 [2.6] for 3 series; 70 [2.8] for 4 series

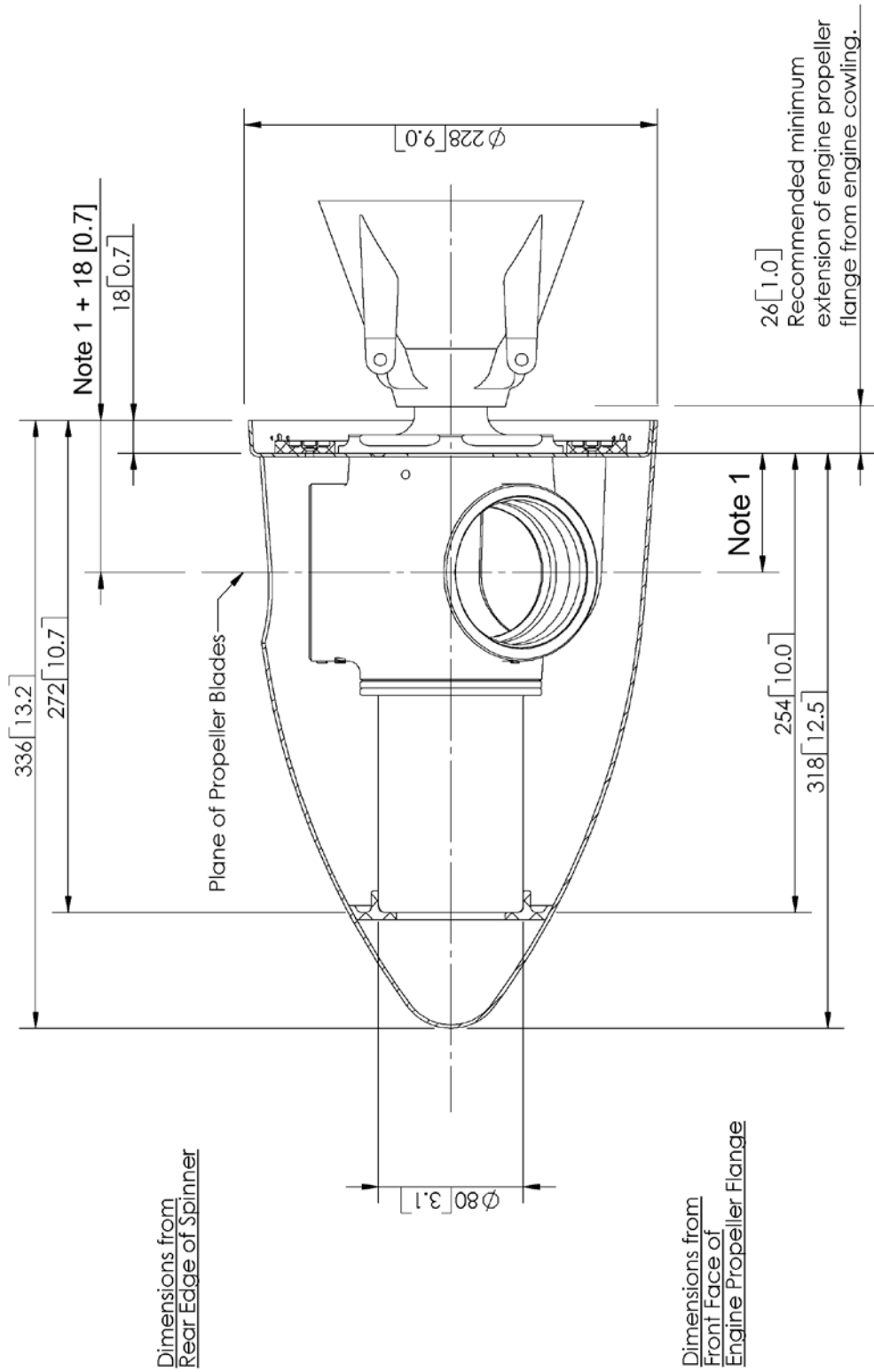

Principal Dimensions of AP332 Propeller with  $\phi 228$ mm (9in) Spinner  
 (Example shown mounted on Rotax engine)  
 Primary dimensions in millimeters [secondary dimensions in inches]  
 Note 1: 66 [2.6] for 3 series; 70 [2.8] for 4 series



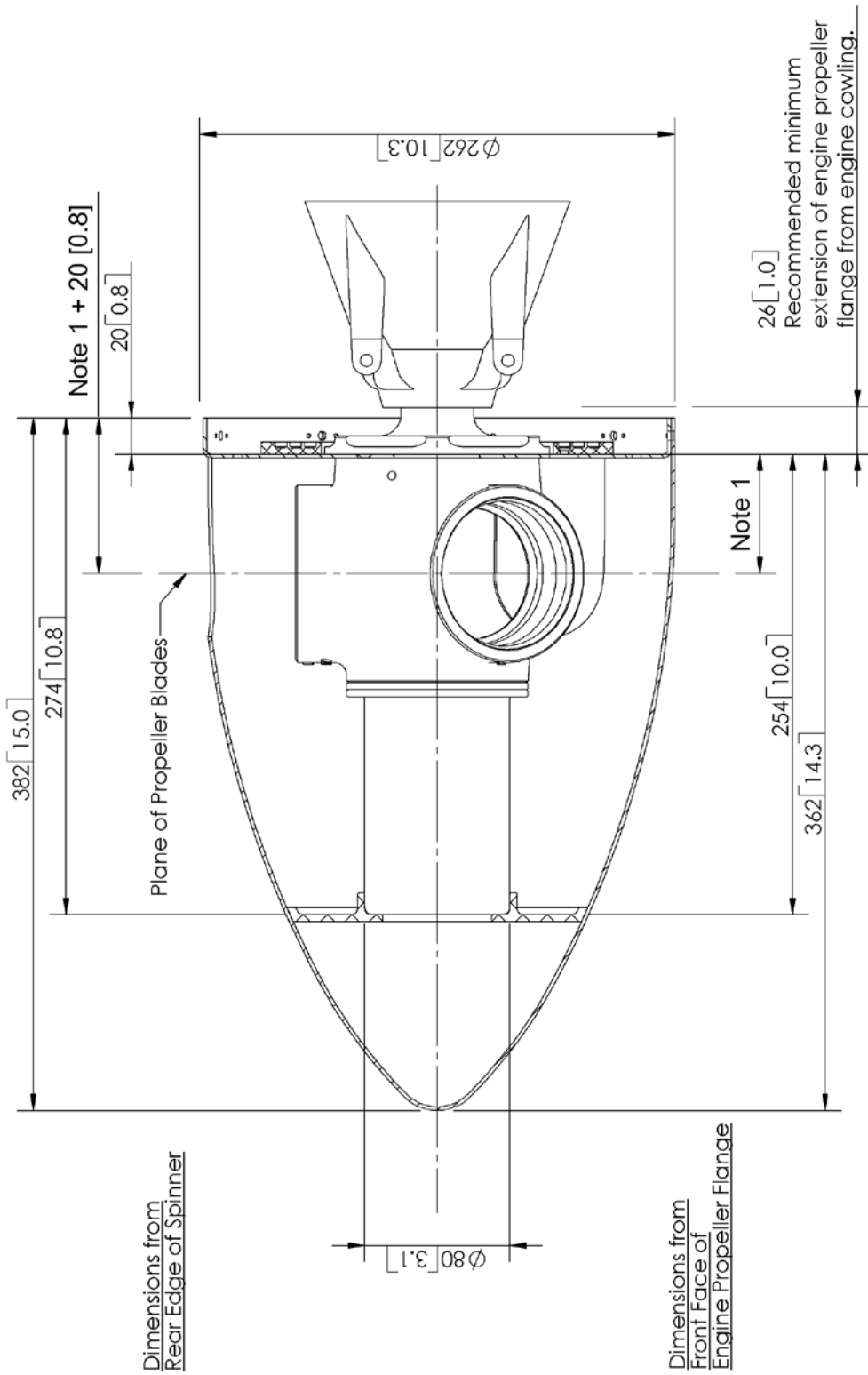

Principal Dimensions of AP332 Propeller with  $\phi 262\text{mm}$  (10.3in) Spinner  
 (Example shown mounted on Rotax engine)  
 Primary dimensions in millimeters [secondary dimensions in inches]  
 Note 1: 66 [2.6] for 3 series; 70 [2.8] for 4 series

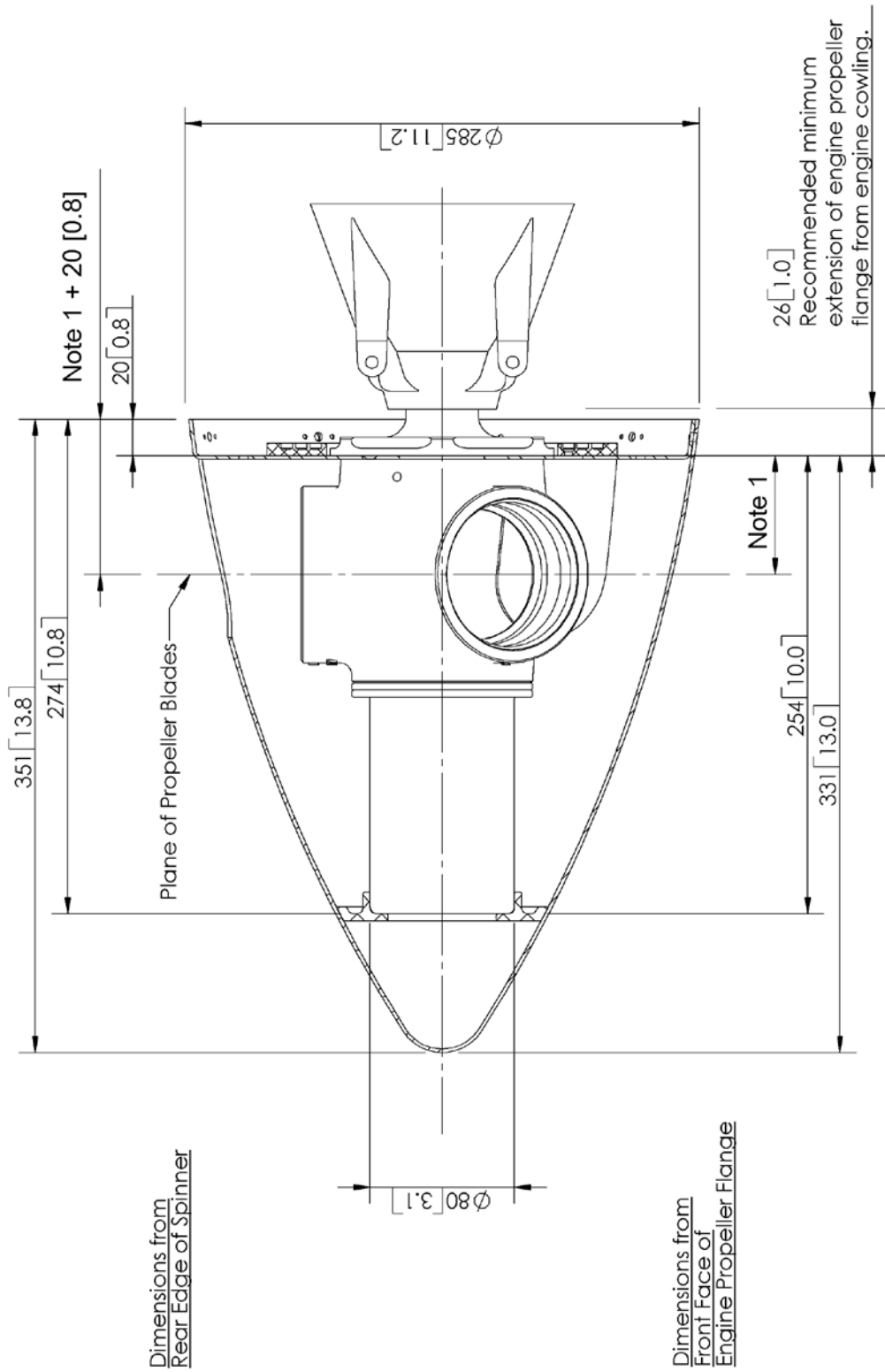

Principal Dimensions of AP332 Propeller with  $\phi 285\text{mm}$  (11.2in) Spinner  
 (Example shown mounted on Rotax engine)  
 Primary dimensions in millimeters [secondary dimensions in inches]  
 Note 1: 66 [2.6] for 3 series; 70 [2.8] for 4 series

## ANNEX B. AC200 SMARTPITCH CONTROLLER CABLES, WIRES AND CONNECTOR PINS

The cables that plug into the rear of the AC200 SmartPitch controller are terminated with plastic multi-pin connectors. The wires in the cables have the following functions and end at the following pins:

Note: Small numbers moulded on the face of the connector where the wire enters the connector identify the pins.

### Power Supply Cable (Connector CN1):

Pin Number	Function	Wire Colour
1	+12V DC supply (from aircraft supply)	white with red stripe
2	Ground	white with black stripe

### Sensor/Brush Cable (Connector CN2):

Pin Number	Function	Wire Colour
1	Speed signal input (from magnetic sensor)	orange/white
2	+12V DC supply (to magnetic sensor)	white
3	Ground (to magnetic sensor)	blue/white
4	Feather Drive (to prop)	orange/white
5	Coarse Drive (to prop)	white
6	Fine Drive (to prop)	blue/white

### Manual Control Switch Cable (Connector CN3):

Pin Number	Function	Wire Colour
1	+12V DC supply (to switch)	white
6	Coarse Input (from switch)	white
7	Fine Input (from switch)	white
8	Ground (current sense ground)	white

## ANNEX C. PROPELLER HUB AND SENSOR/BRUSH ASSEMBLY WIRING

The wires within the propeller hub have specific functions according to the adjustable pitch stops through which they connect to the pitch change motor. The adjustable pitch stops are connected to the controller via the hub wires, slip-rings, brushes and wires within the sensor/brush cable. The following table identifies the hub circuit wiring, and details the relationship between the various parts of the circuit:

<b>Adjustable Pitch Stop Function</b>	Fine	Coarse	Feather / Reverse
<b>Hub Circuit Wiring Colour</b>	Black	Red	Green
<b>Adjacent to Blade Number</b>	1	2	3 (2 for 2-blade)
<b>Slip-Ring Position</b>	Outer	Middle	Inner
<b>Number on Sensor/Brush Circuit Board</b>	3	2	1
<b>Wire Colour within Sensor/Brush Cable</b>	Blue / White	White	Orange / White
<b>Pin Number in Sensor/Brush Cable Connector</b>	6	5	4

**ANNEX D.**

**INSTRUMENT PANEL CUTOUT FOR AC200 SMARTPITCH CONTROLLER**

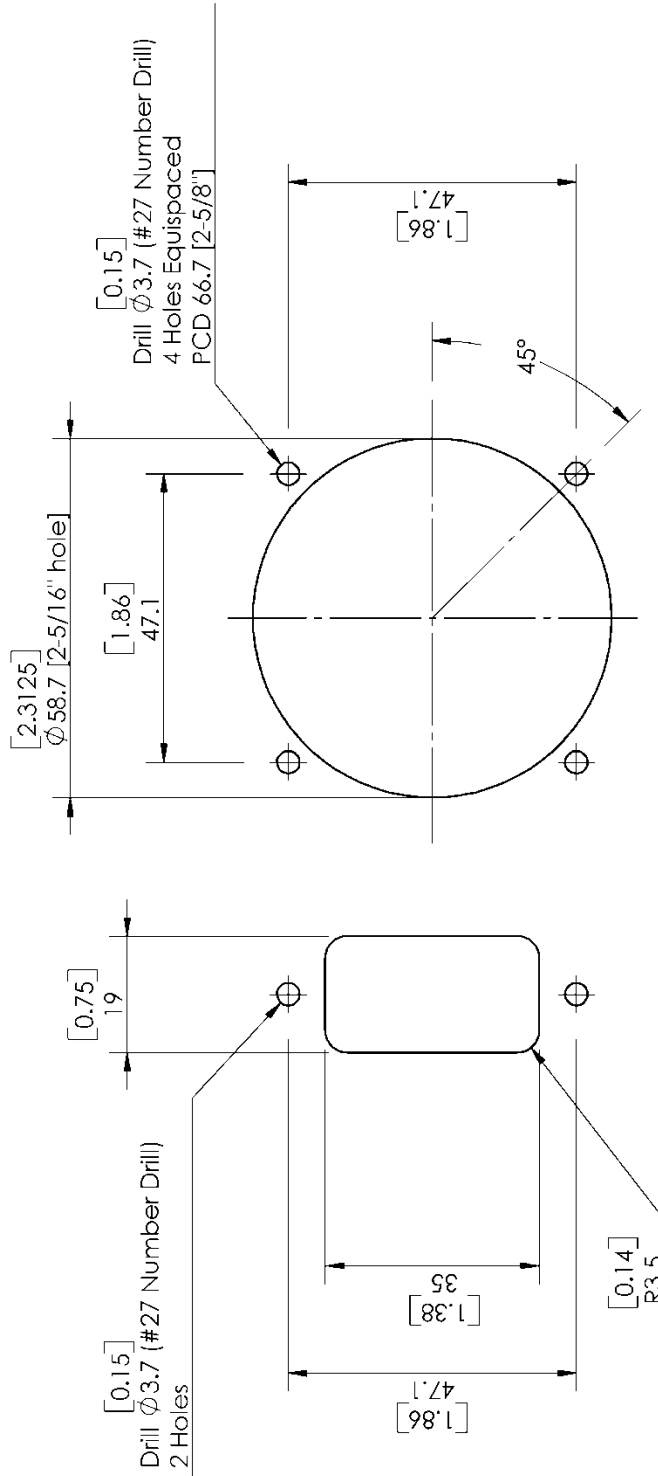

Manual Control Switch Cutout      AC200 Control Unit Cutout

NB: Primary dimensions in millimeters [Secondary dimensions in inches]  
 NB: There is no requirement to position the two units adjacent to each other as illustrated here.